

In Search of Lost Times

Jean-Baptiste Caserta

Oslo Academy of the Arts
Master in Design - Furniture
and Interior Architecture
Afgang 2020

Supervisor: Karin Knott

“We could never have loved the earth so well if we had had no childhood in it, if it were not the earth where the same flowers come up again every spring that we used to gather with our tiny fingers as we sat lispig to ourselves on the grass, the same hips and haws on the autumn hedgerows, the same redbreasts that we used to call ‘God’s birds’ because they did no harm to the precious crops. What novelty is worth that sweet monotony where everything is known and loved because it is known.”

George Elliotts, ‘The Mill on The Floss’

Content

Archives

Froth on a reverie

Where the lace grows

Particles and places

References

Archives

What is left of the moments, the sensations or the experiences that we may have put aside, somewhere in the depth of our brain? The warmth of a ray of sunshine. The elements pictured on our photographs. The priceless values that we used to give to the simplest items, well-preserved in our cellar. I called 'Archives' the collection of intimate memories and shared stories that I gathered and illustrated alongside the work. I asked people around me to share in their own words an anecdote, random or profound, about an object, a place, a memory in which senses and materiality were the essence of the thought. Within a procession of smells, materials, places and gadgets, the testimonies reveal all of the emotional connections that, somehow, feel relatable, lived even. Their descriptions become tangible. Their experiences get shared or understood.

Without regards to the reasons why these people hold this moment, this use or this material, I wanted to define the initial lines of my framework, put words on ideas, on sensations and concepts. Understand the phenomenon. Extract the possible logistic in order to nourish my investigation. Even if disparate in their subject matter, these stories remained a precious reference, a range of inspirations from other times and other minds.

Tree

Do you remember that old tree at the back of our grandma's place? Do you remember how we were always climbing on it?
Creating memories. Inventing a life for ourselves.
You were the kind and I was the queen.
I remember the feeling. Like you're on top of the world. Like you're the tallest and strongest person ever and nothin can happen to you.
We would spend hours in that tree.
And do you remember smelling the food our grandma was cooking through the window? She was smiling at us and telling us to be careful. Always with a watchful eye.
The food, her, our innocence would give us a sense of comfort, a sense of protection.

The years passed, we grew older, the tree became small, the smell disappeared and so did the smile behind the window. But when I find myself at the place of our grandma now and I look at the tree through the kitchen window, I can't help but remember the good time we spent on that tree.
A symbol of our happiness, a symbol of our kinship.
When I think about it now I can't help but have the perfect image of it.
I see it as a slow motion noire scene. The sunshine sparkling through the leaves, the movement of the branches as we were climbing, the smell of nature, the dirt on our clothes and our smiley faces.
It makes me nostalgic but not in a bad way.
It makes me happy. It brings me back to a happy place.
One where we were still close, one where she was still there, one where everything was easy.
And I can't help the smile that appears on my face. The same one that she had.

Océane

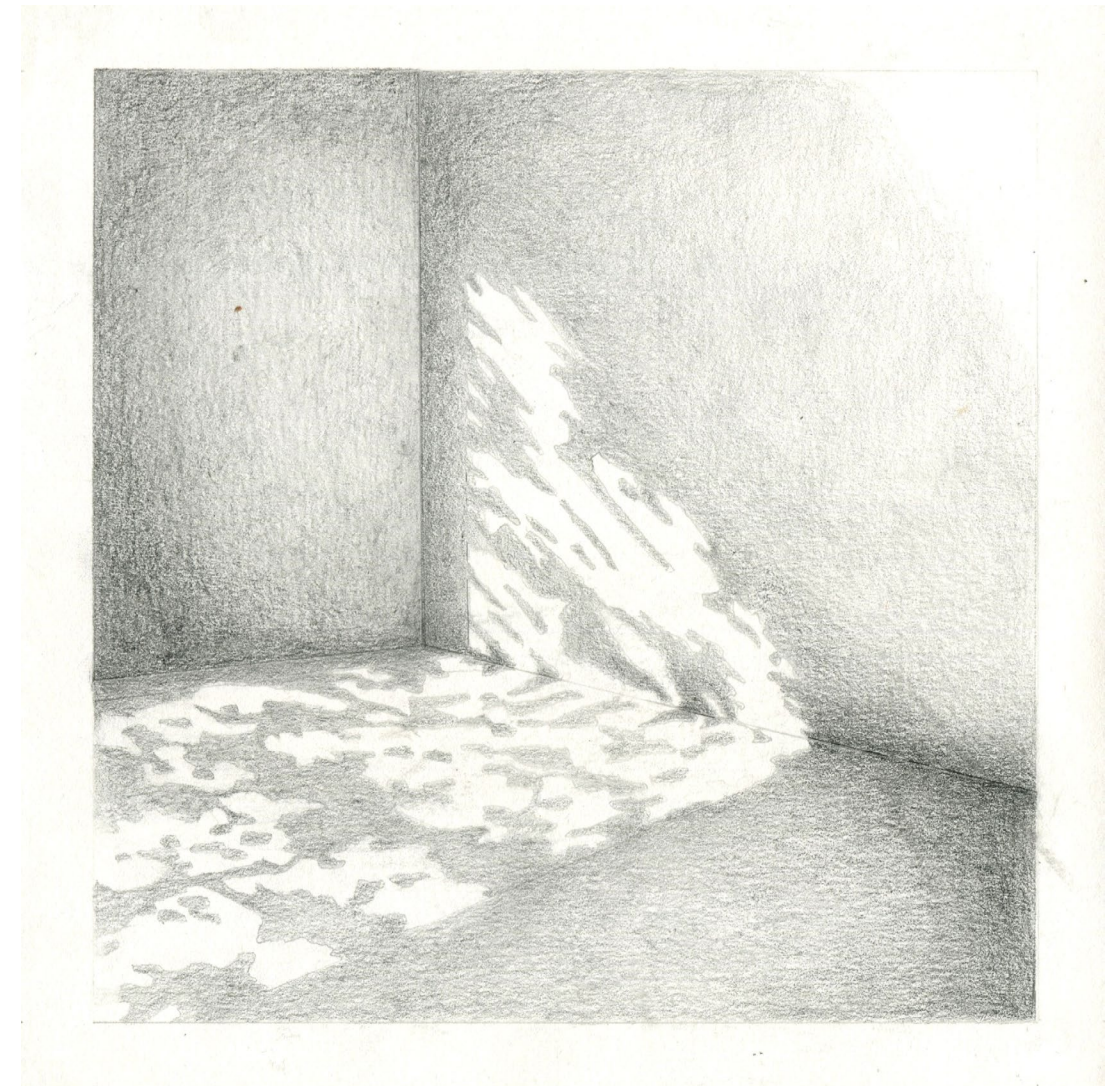

Polyester

I somehow thought about the fabric that is used on the tent. You know, that sticky, smooth, shining type of fabric that has this very tactile feature of absorbing all the moist that is in the air, outside or in the tent. All the breathes, all the fog, the cold of the night. I think about the frost it keeps on the absolutely too warm to sleep in the tent even with an opened zips, morning, when I still do it, too afraid of being bitten by ants. The air not floating freely through it, the air backed into a corner. Or I think about the time when I stare at the "ceiling" and see rain drops falling down from the rounded dome. I especially like these moments. The way the rain sounds - I don't want it to ever stop. How fresh and moist it becomes inside, how nice it is to breath, how I feel protected alone in my safe dryish world but with wetness at my fingertips. It's enough I raise my hand and the fabric leans towards me. But if the rains stops and I want to move forward with my trip, then I have to touch the tent and the fabric will stick to my hands and my naked legs, uncomfortable touch with its wet stickiness. Or I think about the times when the fabric is being blown away by the wind as I try top put the tent on the ground. It is nothing, it has no shape, it just flies, I may want it be blown away because it is so nice to watch. As I fight to make it in a shape I need and how it gives up as I pull strong enough and make this characteristic sound. Such a not pleasing material, something I wouldn't use anywhere near my to attract the touch, especially in this awful rotten green color that my tent is, still useful and strong, connected to so many memories.

Ada

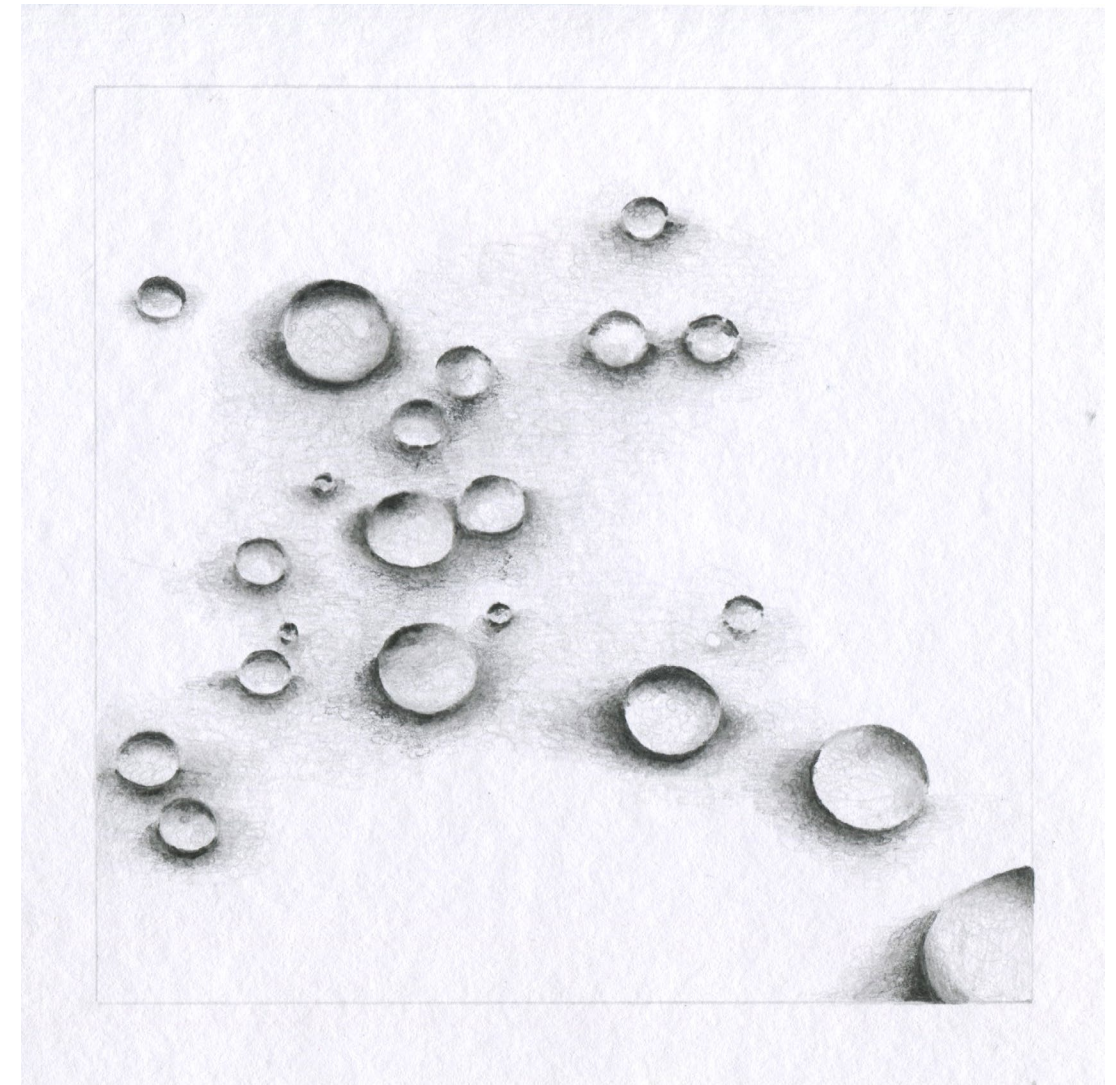

Box

It was always a race. We had to put the CD in, click play and then, as fast as we can, climb from the side of the couch to the top of the chest before the music start playing.

It was our stage. From there we could see the couch and all the way to dining room. We were rock stars, as the music played, we would show off our best choreography, often accompanied by the beat of the metal handles and the sound of our feet stomping on the hollow chest.

It was our island. When the rug and the wood flooring would become lava, and the only safe place was the couch and the chest, we'd grab the metal handles and get up there, waiting for the eruption to pass.

It was our diving board. Only the bravest would stand tall and dive from the chest to the sea of pillows laid on the ground.

It was our resting wall. It acted as a pillar for the countless sophisticated pillow and blanket castles we built to hide.

It was our safe haven, our throne, our rock.

But it was also a mysterious and dangerous artefact. We had heard stories about what it was saving. What was inside? A treasure long lost by ruthless pirates, dresses prettier than the ones in Peau d'Anne, exotic creatures brought back from every corner of the earth. Many times we tried to open it, but the weight of its door was too heavy for our little arms. We could barely lift the rusty locks on the front using all our strength.

It was also dangerous. To this day I still bare the mark of the chest on my forehead. Reaching the top before the lava eruption or the beginning of a song often led to accidents and collision between the sharp wooden corners of the chest and many parts of our bodies. It was also particularly vindictive towards our toes, leaving us at its feet, crying for help.

But it was our chest. This big wooden box, with great bolts and locks, straight out of a pirates story. Symbol of the many adventures we had, symbol of our imagination.

Manon

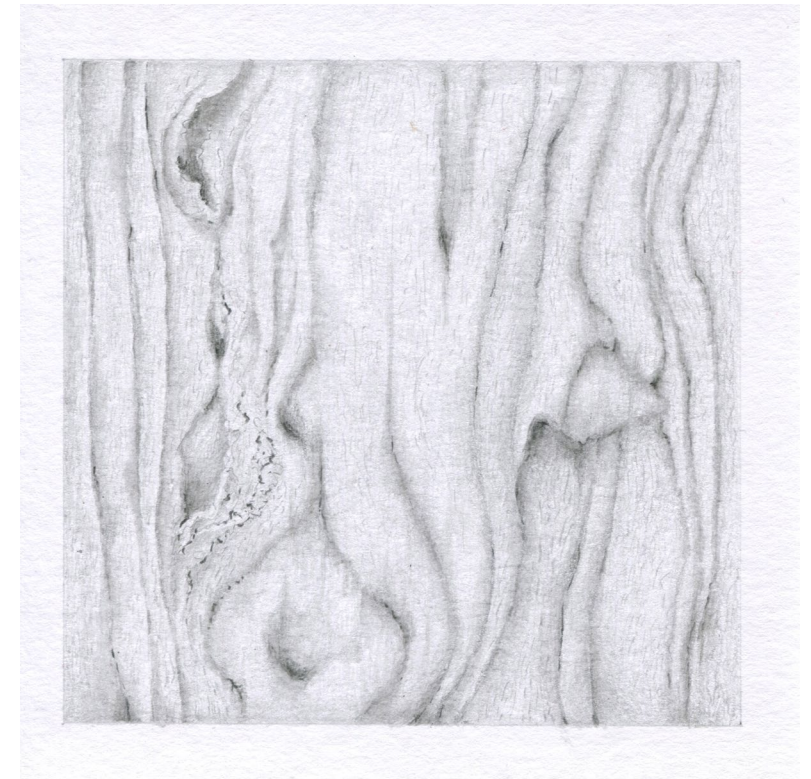

Jewelry

objects do those things I want them to
believing enough before I turn off the switch
giving into their niche
just to escape my clarity
step away from reality
for long to disappear
I rush to grip onto the control wheel until you gave me this
gold and cold
little yellow bliss
travelled from quite far
so that you can reach me somehow
in hard times
like bones and see-through skin destroyed
to remind me of the bond
that will never shed
that distance have no control of seemingly unbothered
I placed it close to the heart
to slowly feel its warmth
saved from many sorrows
easing my swollen throat sanctuary slab
in the wildest moments belonging to your tribe
as we hold hands
and swing each other's braids
our fluoride faces
kiss on both cheeks
and a tight hug
to say goodbye again
I carry you with me
to forbidden lands
as a totem of life
that brings tears into dry eyes bloodlines
a burden from you that
I will cherish til I fly away

Veronika



Shelves

To tell you the truth I am not the most nostalgic person. This isn't due to any childhood trauma or absent parents. I, indeed, had a perfectly happy childhood and yet, I never attached any sentimental value on things. Neither today do I hold a strong sentimental value on a thing from my past. To try I understand why, I have looked into the psychology of things for children. Some researchers believe that in early childhood, the attachment we have to objects is a mean of being more independent. These objects are therefore called "transitional objects". With this information I can tell you that I have always been somehow independent. Very early on, I loved being alone, independent and away from my parents. For example, I remember travelling alone for the first time at age 6 and it felt like the most exciting thing that had ever happened to me, I was so proud to be able to fly alone. This helps a lot in understanding why I have not attached a very strong sentimental value on an object of my childhood.

I don't go back often to my parents' house in Nice; I should make the time but the world is a busy place and it only becomes busier. Yet every time I come home, or maybe I should say to my old home as I have built mine in a new place. I find myself sitting on my bed facing my bookcase. This bookcase in itself isn't anything special, I did not inherit it from a relative, it was not bought from an antique shop and most certainly, it wasn't expensive. In fact, it is the billy bookcase from Ikea. To emphasize its ordinariness, it is estimated that every five seconds one billy bookcase is sold somewhere in the world. It is a very standard and straight 40x28x208 bookcase in a material that I would assume to be wood but it does not feel like it to the touch. It is also made in a robust white colour that reminds me of the Bic white-out correction tape or liquid pen that was all pupils' best ally and that all school teachers hated because it made papers look messy. The billy bookcase is unremarkable but on a positive note it is simple, functional and it was perfect for my books. I have always loved reading, ever since I can remember. Sadly, it never helped me in my French lessons at school, I always had mediocre to acceptable grades but I never gave up reading. My books have travelled with me to far places in the East and West. They have been with me through health and mental health issues, through laughter, tears and aches. I never felt alone and never minded being alone because I always had a book with me. They have always been a great hiding and protecting tool from people, especially on public transport. Trust me, they will protect you from making the awkward and dreadful eye contact with the pervert stranger on public transport. If you took a look at my bookcase you could probably see the different phases I went through in my life of an almost 24 years old woman. They have continually changed and evolved in symbiosis with me. So yes, I must say that I attach a nostalgic emotion to my bookcase and all the books it holds.

Lina

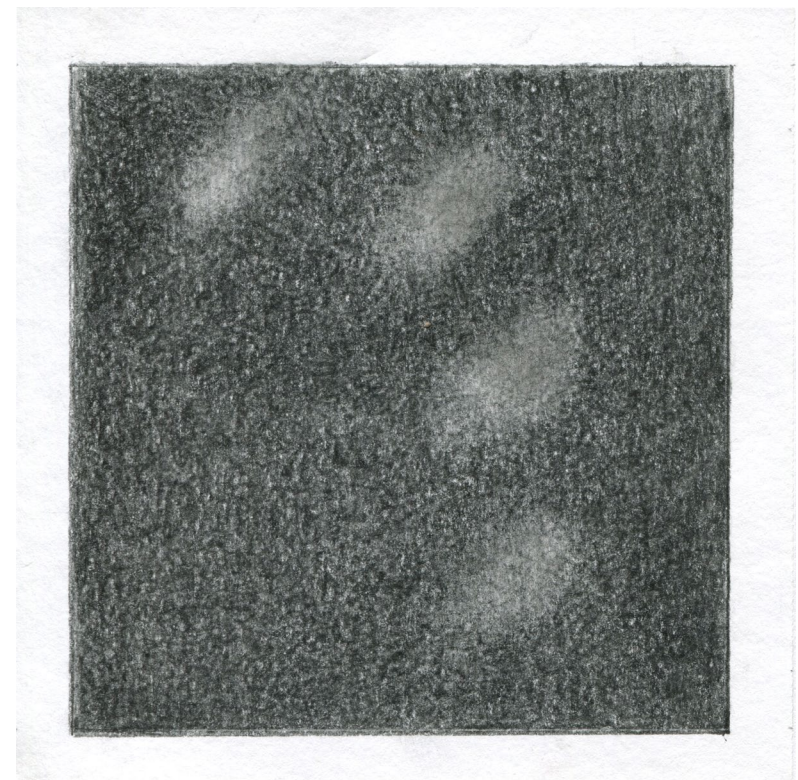
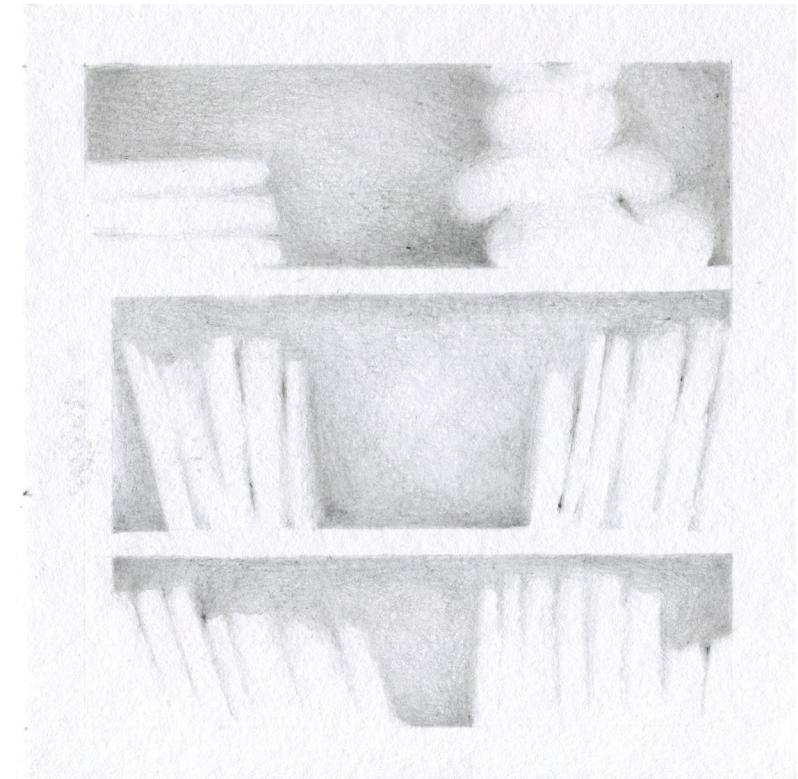

Pillow

I remember these mornings, almost as precisely as I remember yesterday. The sun would timidly pierce the horizon, behind the half-open windows, when only the birds were awake. She'd come in the room, letting the lights of the corridor invade my darkness and, very gently, wake me up. It was never easy for me to wake up early - and for my parents to handle me. It'd take me long minutes before leaving the comfort of my bed.

I remember when we'd leave the house in single file, facing a summer dawn just as pale as my tired face. We'd carry our pieces of luggage to the grey car, where my dad would spend half an hour finding the best way to organize the overflowing trunk. I remember exactly the heavy smell of the black leather, so invasive it would practically become unbearable. This distinctive scent of the car seats, however, meant summer holidays to me, these long trips across the country I grew up in. We'd go far from home, to regions I'd have never heard of, to villages almost invisible on the map.

But as far as we'd go, as different the landscapes would be, I'd never really leave my bed, simply because I'd carry my pillow. This piece of fabric and feathers would not only improve my comfort during these endless hours of driving, but also remind me home. It would remind me that, even in places I couldn't put names on, I'd belong somewhere. That I'd have unfinished stories with my toys. That I'd have a piece of home that no one could ever steal from me. After all, I'd never really leave my bed.

Nicolas

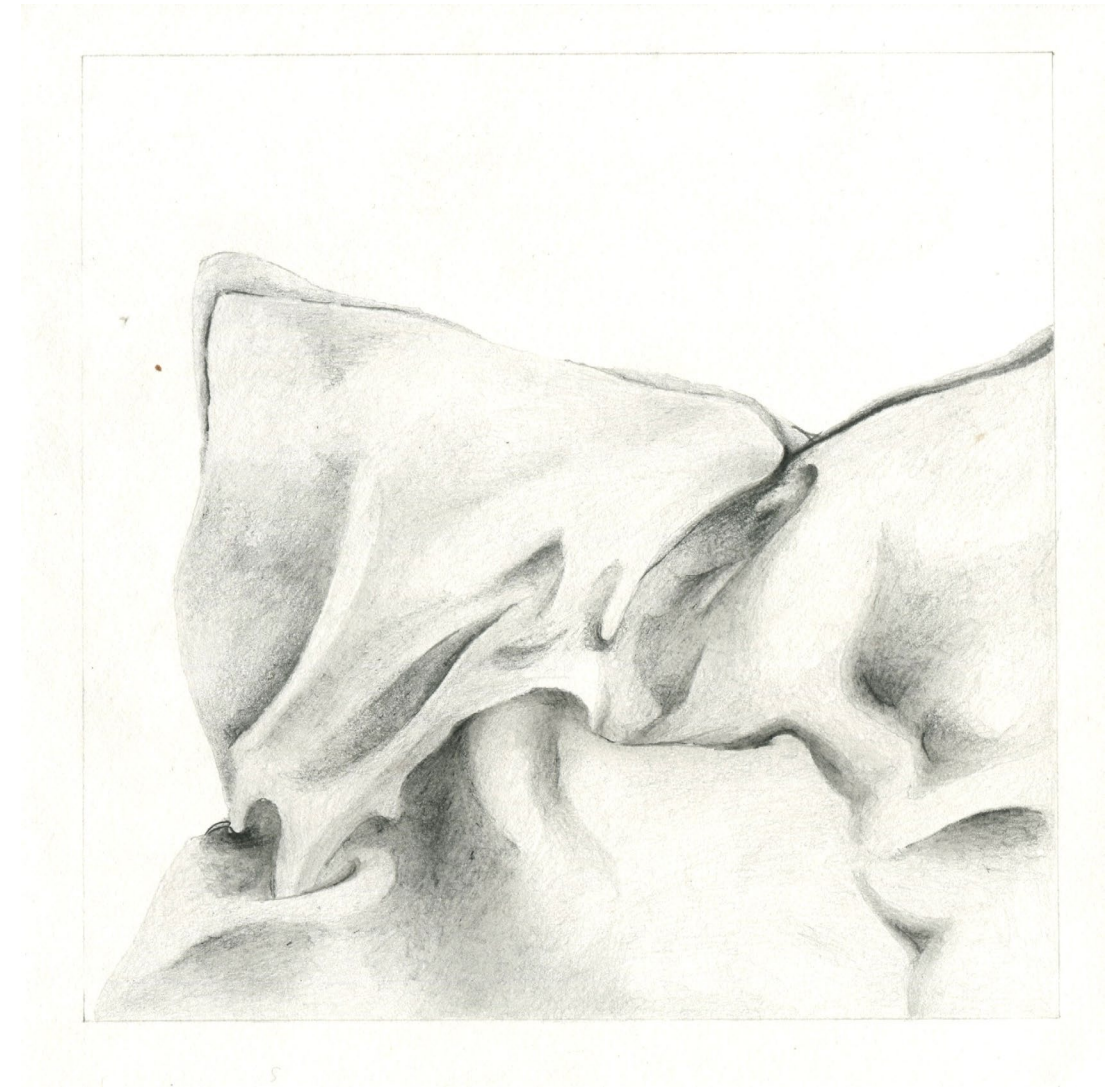

Garden

I was eight years old. I can still see myself in the garden of my old home in Nice. The word 'garden' is too weak. I'd rather call such a vast space a 'park'. It was an idyllic place that four huge umbrella pines were keeping safe. They were big and majestic. They actually impressed me. I can still smell the fragrance of the sap, and still hear the singings of the cicadas. I remember myself, as a little girl, grabbing a stone in order to break the shells of the pine nuts. Everywhere, hundreds of them were scattered around the ground. And suddenly, I can almost feel the delicious taste of the pine nuts invading my mouth.

Lisa

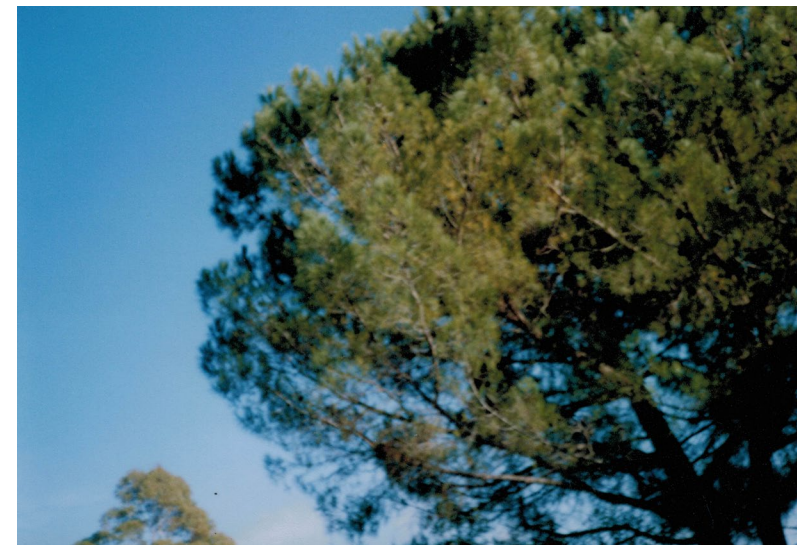
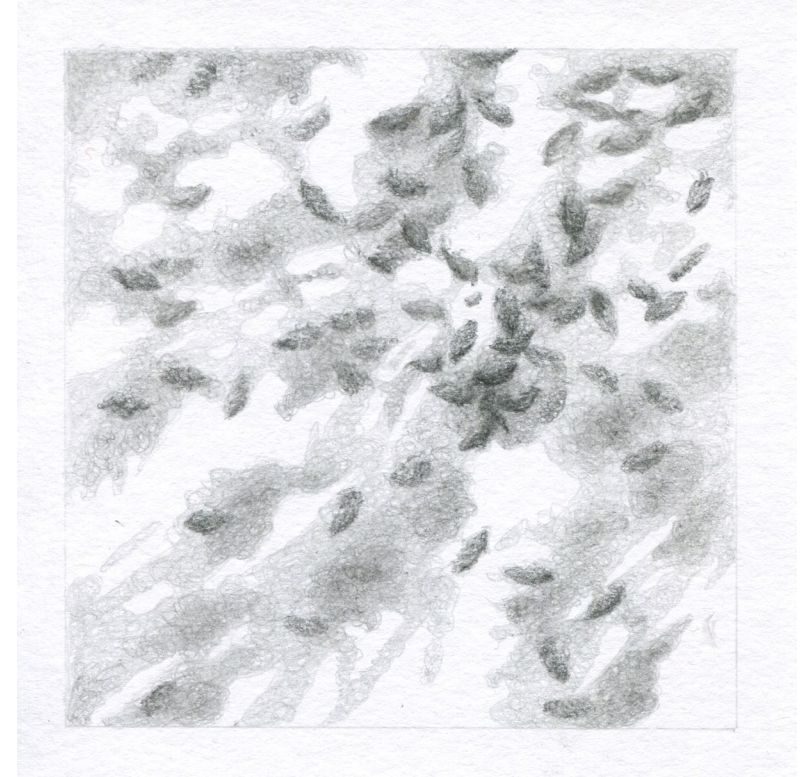

Coffee maker

First, the smell seizes me as I enter the room. A grilled grain scent, chocolate-flavored, with a hint of caramel. The bitter-sweet odor of a newly-ran coffee. Then, the sounds come to me. The crackling of the flames coming out of the gas burner. The murmur of the brown liquid streaming into the containers meant to collect it. The jingling of the many and varied cutlery and kitchen utensils. The oblivious rustle of a conversation that had just been initiated. The slight tumult of the beginning of the day. And, in the middle of all this calm restlessness, an aluminum Italian coffee maker. All dented, a result of the falls and knocks from several house moves. Like a timeless beacon, it has been taking the center stage of the kitchen for almost twenty years (first my parent's kitchen, and now in mine). It acts as a silent witness of shared moments, of unintentional solitudes, of under-way days, of finished meals and prolonged nights. An ordinary totem of common rituals.

Guillemette



Froth on a reverie

The sea remains an omnipresent character of one's vacation memories. The sand castles. The walk along the shores and beyond, the flat horizon distorting the blinding sunlight. What I called 'Froth on a Reverie' is the very first step into the material development of the project. I was exploring light and reflections as possible tools for an immersive contemplation: an emotional experience where the effects of lighting would allow different readings of the same display. The idea that an undetermined form can remind one of something. The intimate feeling of a familiar vision, whether it is personal or not.



Somewhere on a vacation.
Family picture. The last swimming of the day, when the tourists are gone and the sea merely feels cleaner, vaster even.

I became fascinated by the emotional potency of the sea, unmissable figure of poets, regular comrade of vacationers. It is the sea view, the strong taste of salt, the distant sound of slapping. It is the excitement of being afraid of it and yet, still being drawn to it. It is the mirror where the sky expands, vaster and brighter, and everywhere around — as if no one could avoid it— its reflections animating the hulls or the houses.



Picture from **The Anonymous Project**, anonymous photograph

Something was there, the qualities of a distinctive feeling, the idea that there is always something to contemplate over its endless horizon. I wanted to materialize the interactions between the water and the different lights of the day and the night, where reflections and colors offer a variety of perspectives. A series of experimentations and questionings on how the emotional potency of the sea could be captured and translated in materiality.

Evoking the wave

Material experimentations on a lighting filter

Silicone
Shiny material

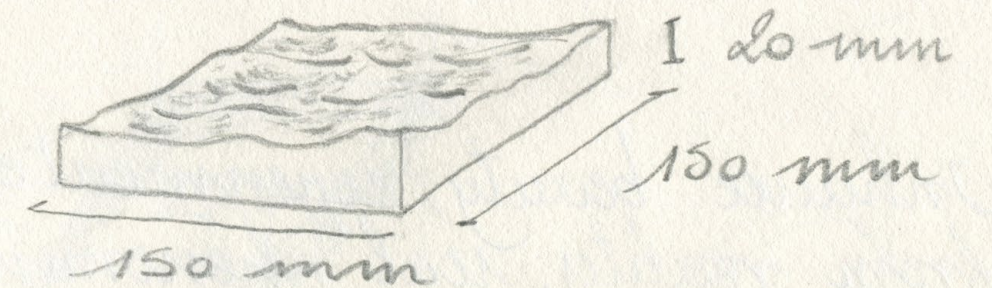

Premier moule en max, deuxième en silicone
Mélange de couleurs possible

Essay #1: impression 3D.
impression 3D du moule pour une précision max

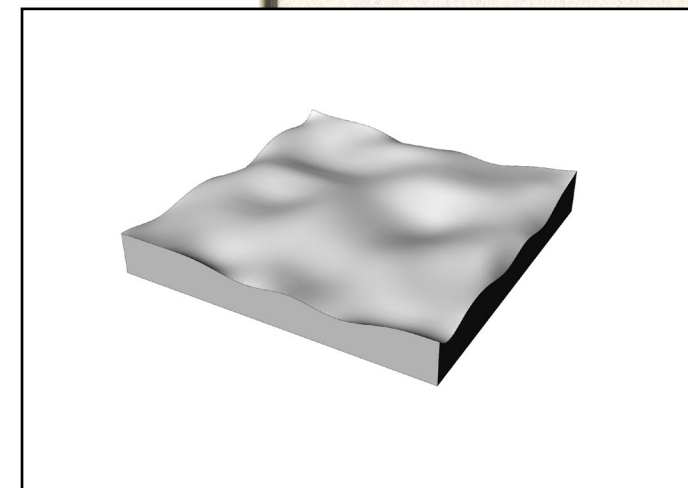

3D rendering evoking the movement of a wave

Epoxy



Digitally printed plastic
(160mm x 160mm) molded
in silicone



First epoxy sample
(160mm x 160mm)



'Light boxes'
Tools for experimentations
160mm x 160mm

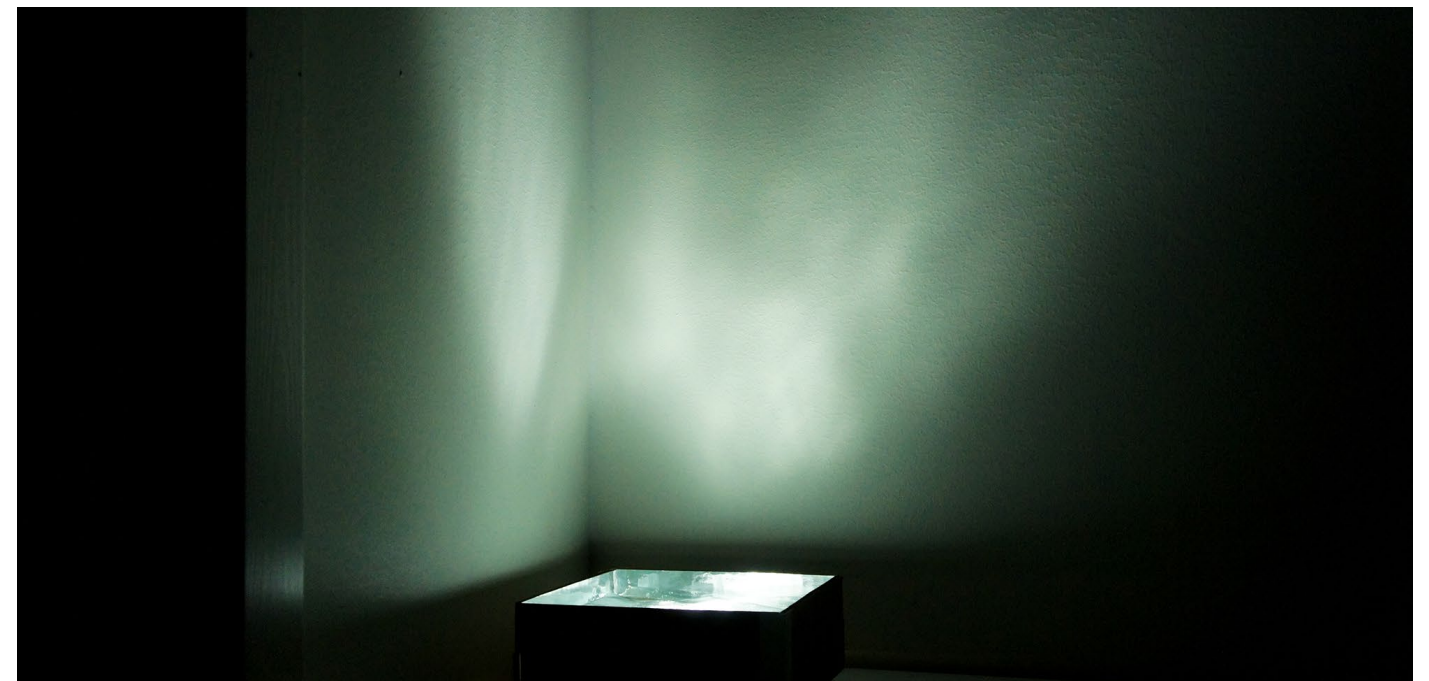

Interaction with epoxy and
artificial light

Silicone, first experiment



Cut pieces of transparent silicone on a plexiglass slab (160mmx160mm)



Close up of the silicone cuttings



Interaction between an artificial light and the pieces of silicone

Silicone, second experiment



Sample of silicone (160mmx160mm) molded in a cardboard covered with crinkled aluminium papersquare

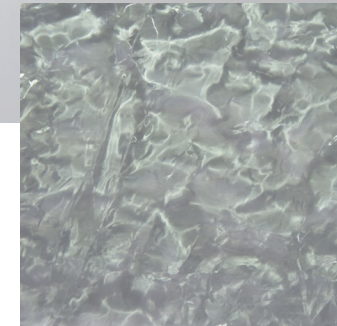

Close up of the silicone sample

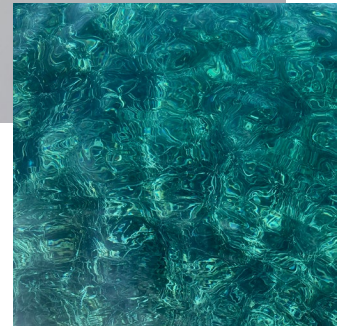

Surface of the Mediterranean sea

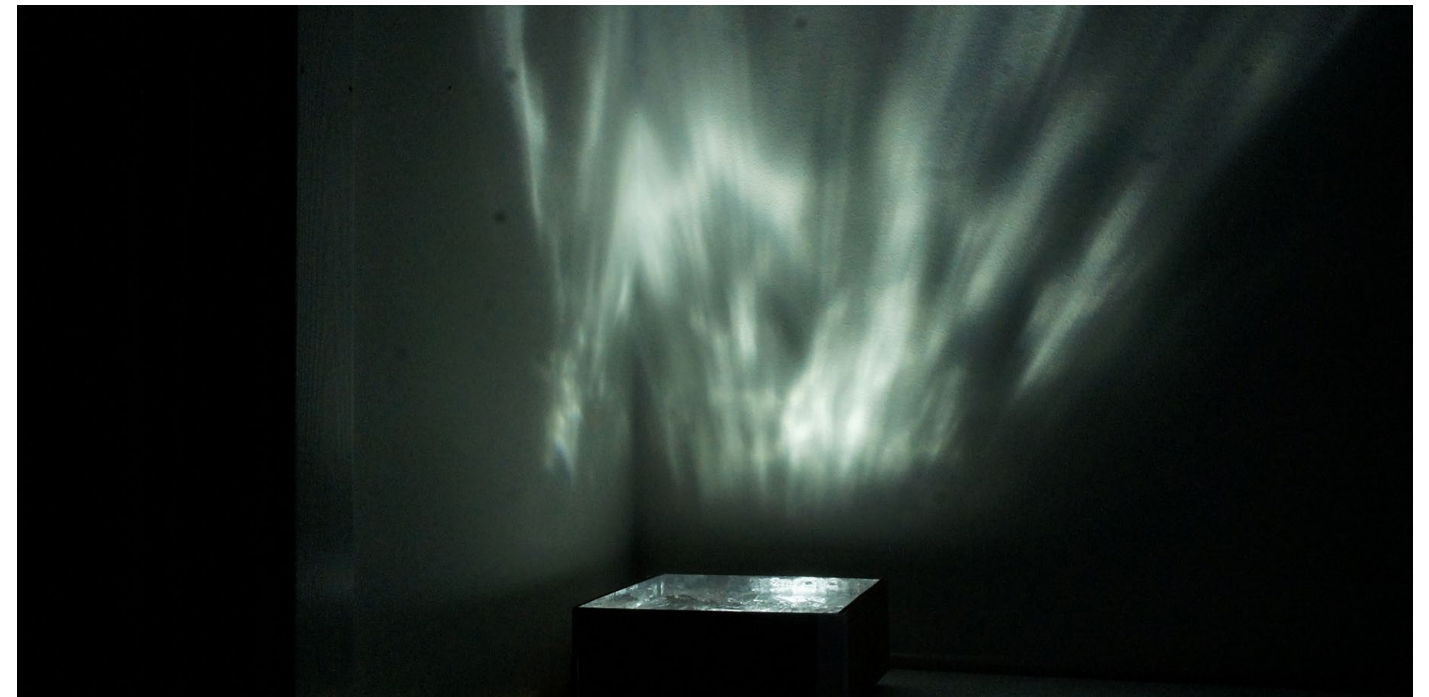

Interaction between an artificial light and the silicone sample

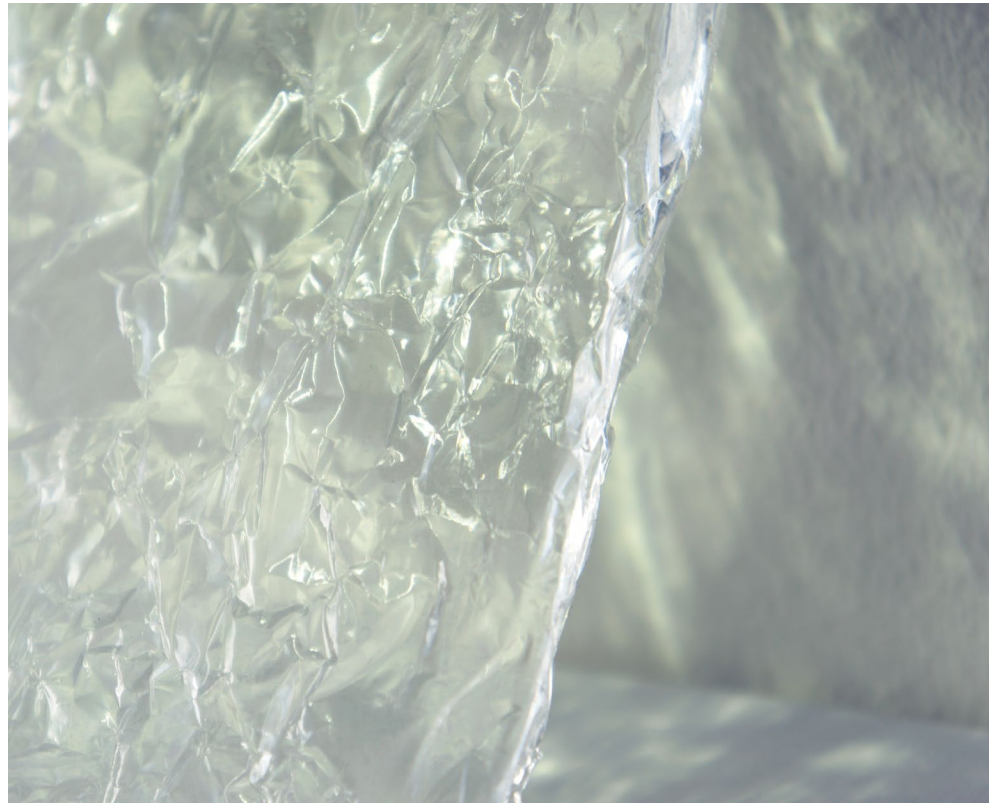

Reaction of the material with natural lightning



Reaction of the material with artificial lightning



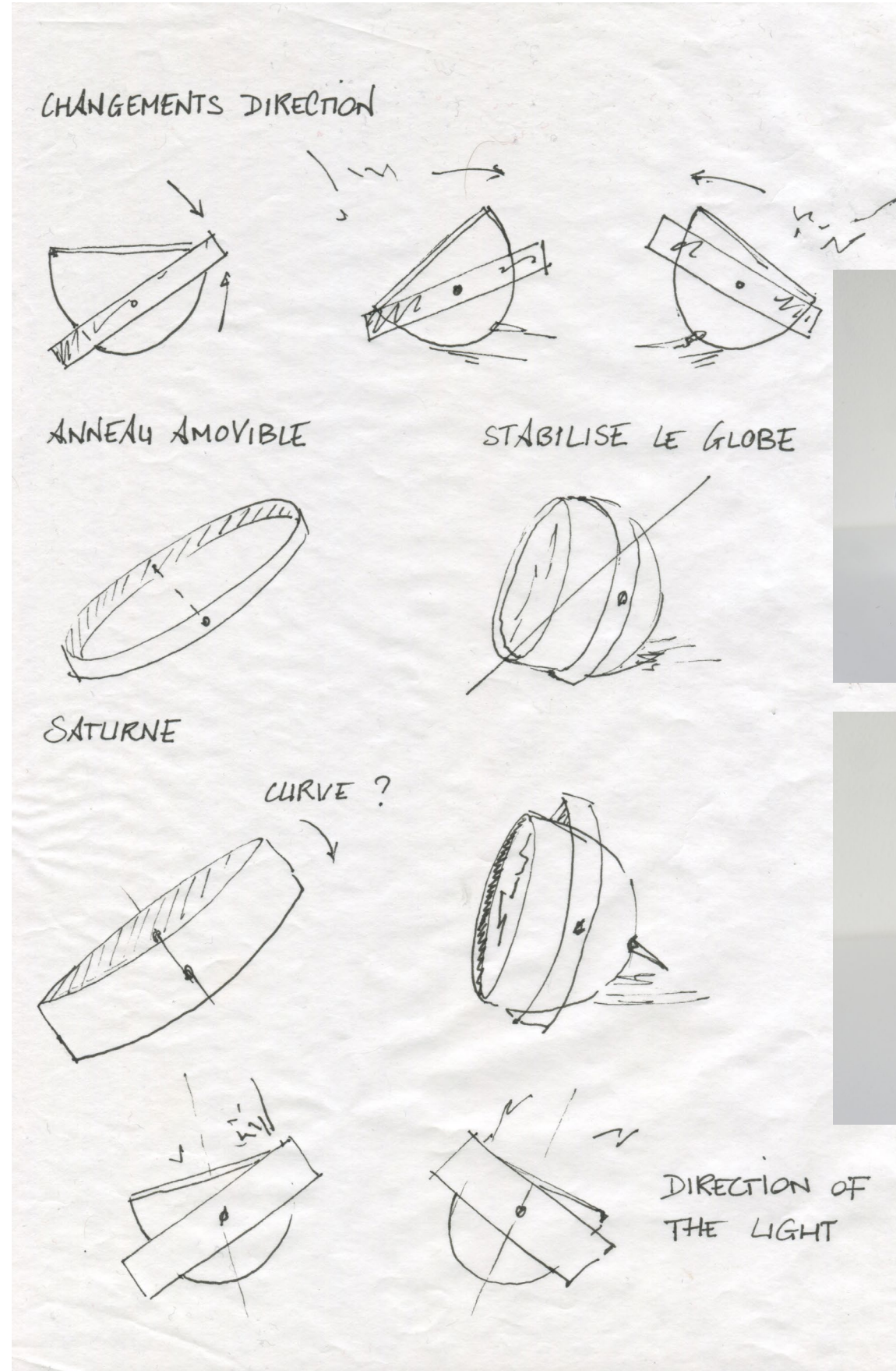
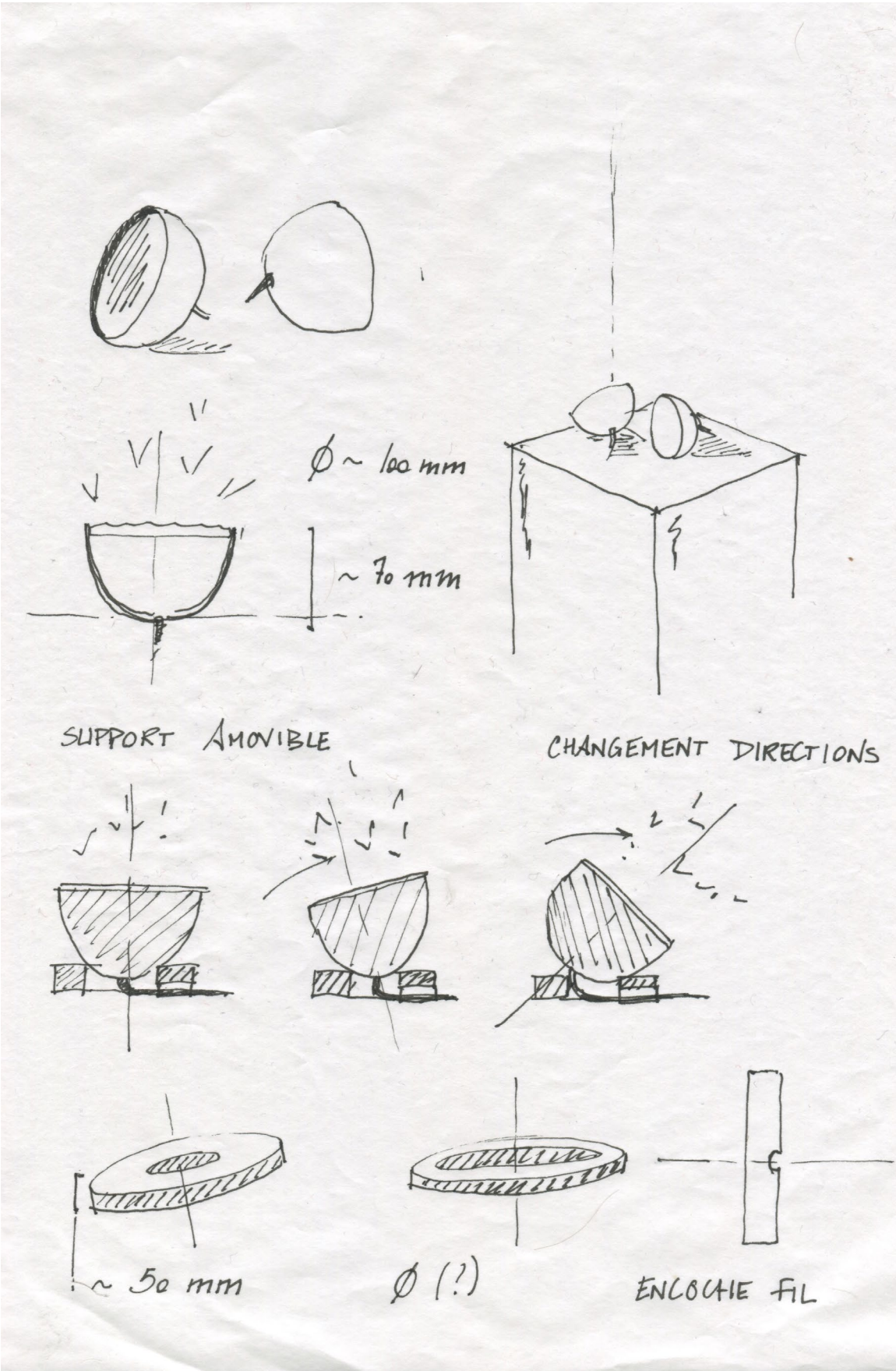

The 'experience container' consists of two pieces. The first one, the stainless steel bowl holding the filter, enhances the power of the light. The second one, the wooden ring, serves as a movable support that allows different angles for different reflections.

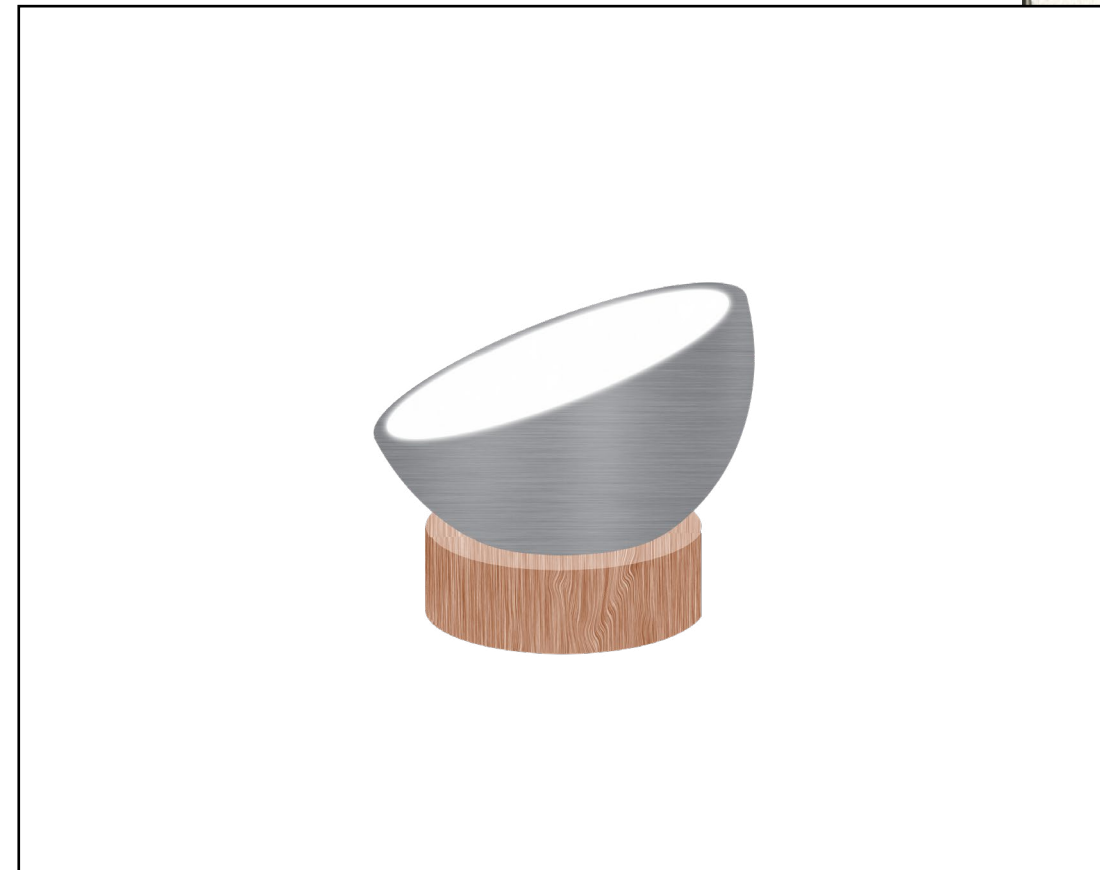
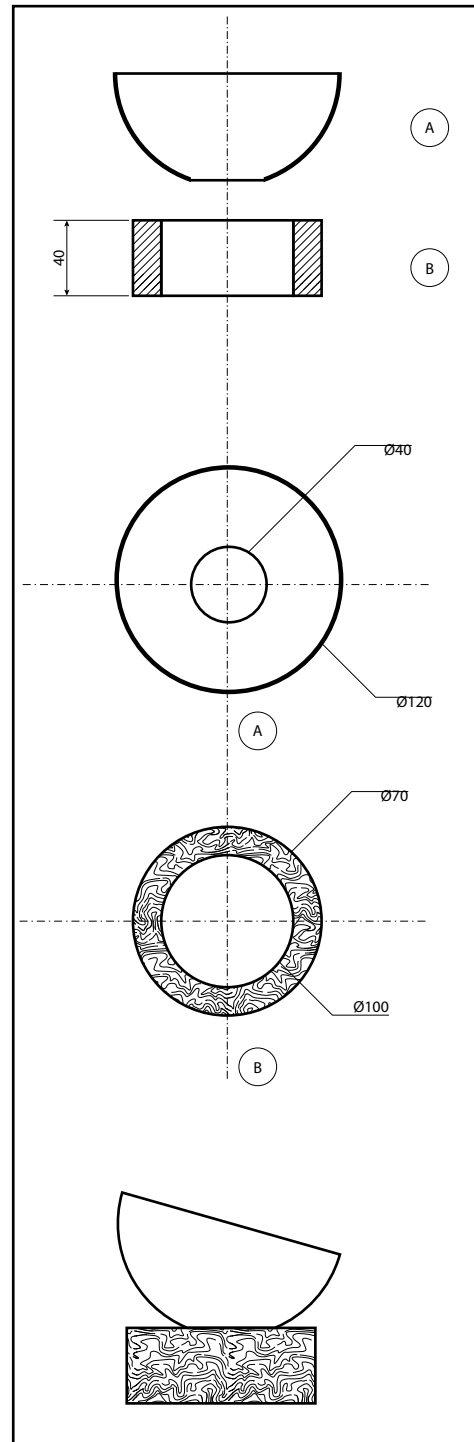

In a similar approach to the night-lights that not only play with the lights, but also happen to be an emotional support for babies, I imagined a small lamp suited for bedrooms. A context where dream and memory merge, both in terms of perception and visual effects. I wanted the experience to remain intimate, far from invasive.

@ Lampe
 metal; plaster: molding
 silicone.

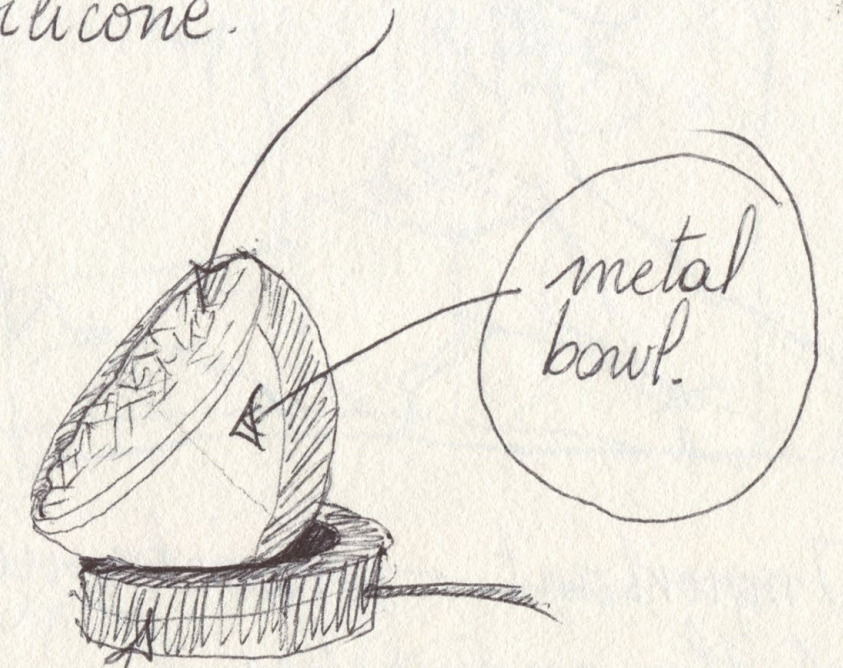

wood support. (CNC)

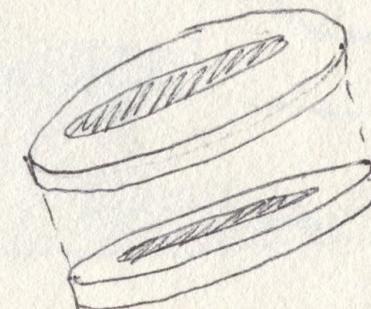

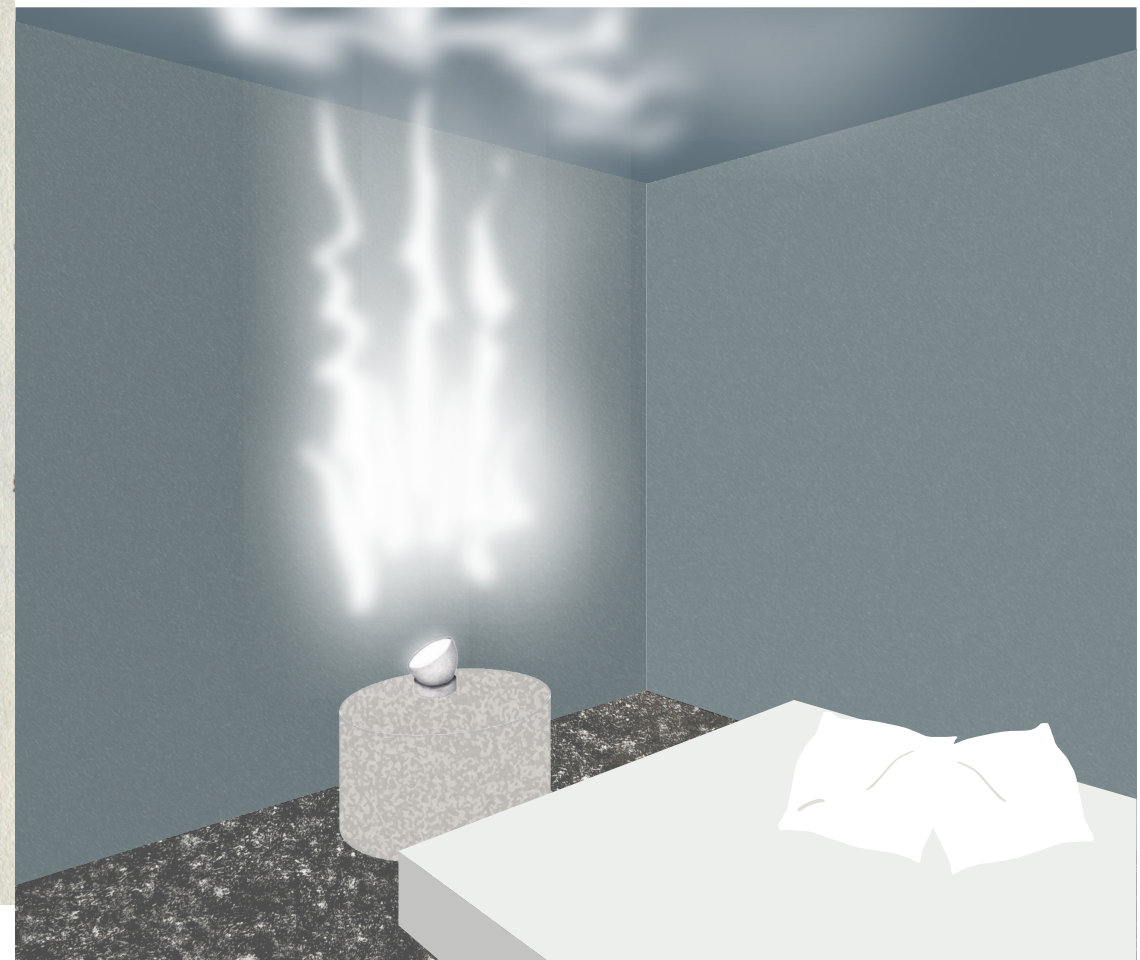
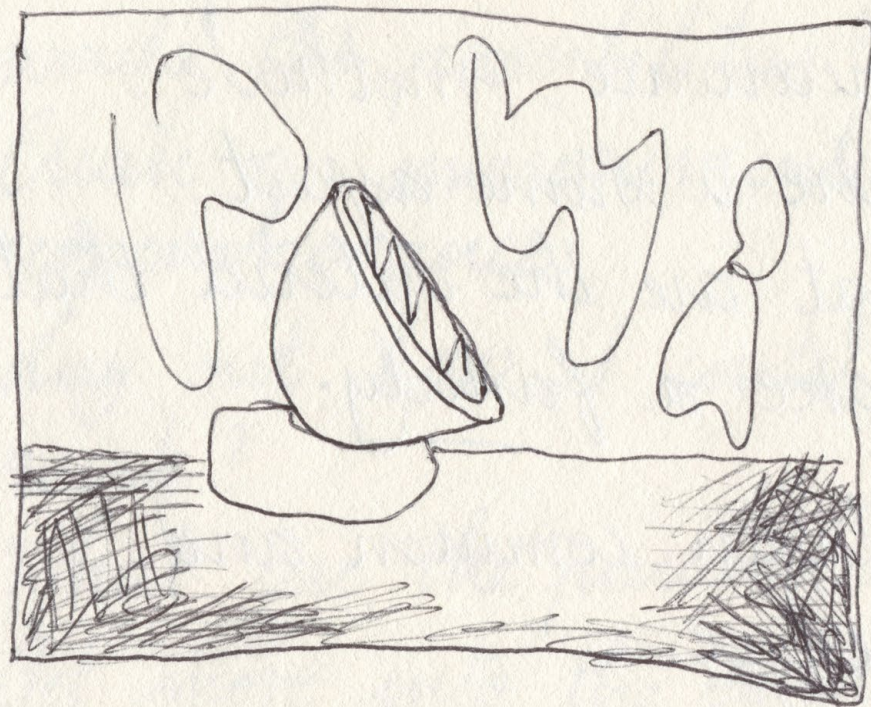
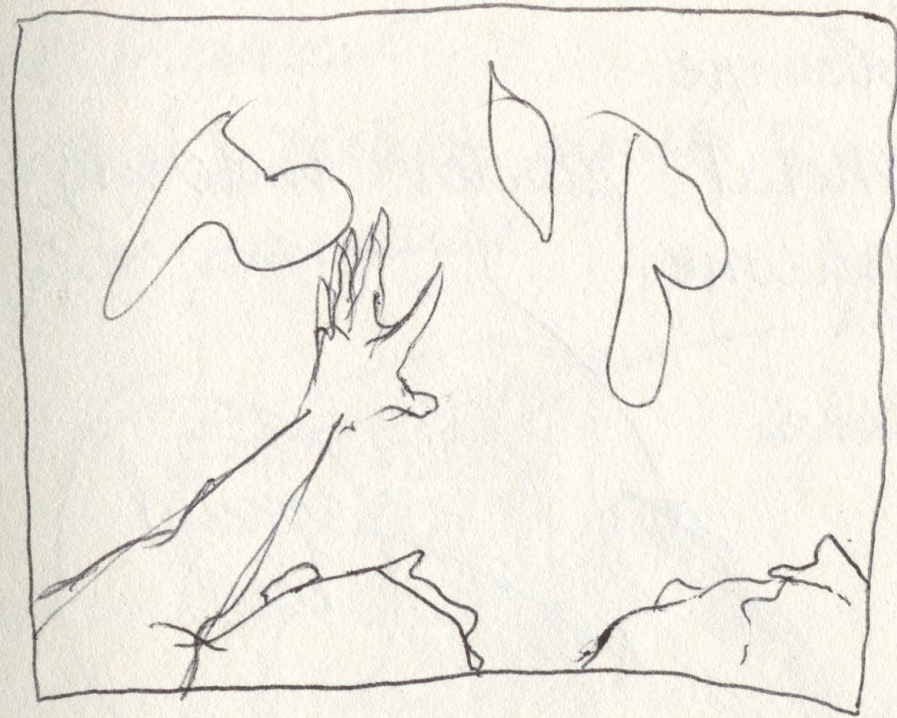
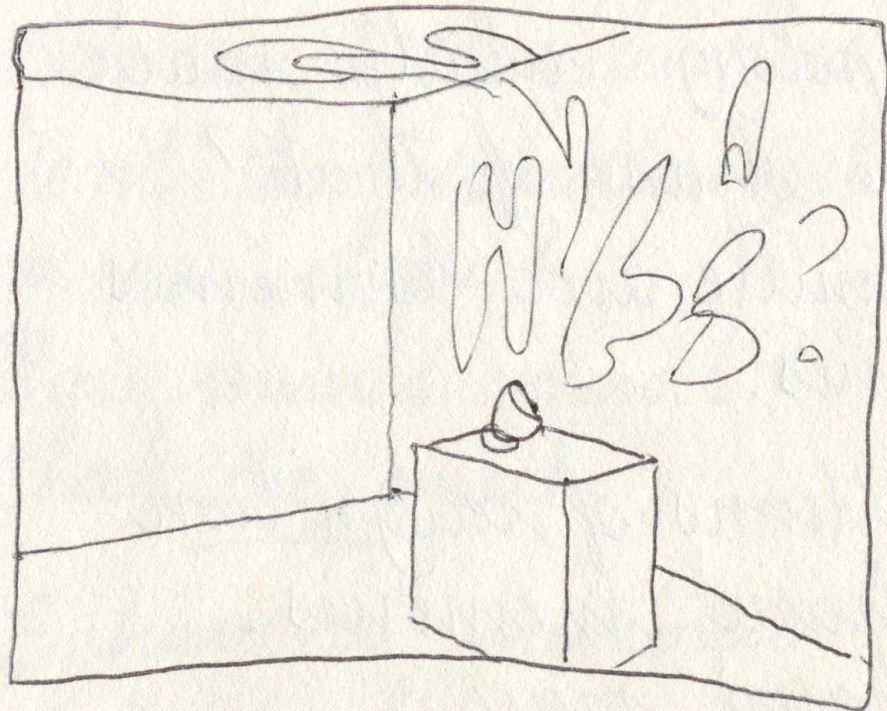



Format: GIF
Link [here](#)

Where the lace grows

In the same approach to 'Froth on a reverie', 'Where the lace grows' enhances the emotional features of ordinary elements. Whereas the first aims at transliterating the qualities of lights, the second addresses the qualities of shadows.

The tree resonates in memories as a totem of engraved experiences. The hut in the tree. The nap under the leaves, where the rain is unwelcome. The morning light slowly inserting the moving shades in a corner of the room. And its lace, foliage in perpetual movement, forms the intimate space of a reassuring presence, a daily play of shadow.

Moving on with the project, I wanted to develop further the idea of an 'object of experience' with the hope of engaging a deeper immersion, both in the space and the mind. A closer inspection on the materials and their sensory qualities.



Family picture.
Somewhere in Provence or Corsica.

Textile and transparency

Baking paper cut forms on a polyester organza piece



Sewn forms on a polyester organza piece



Polyester organza leaves-shaped forms sewn on a the same fabric



ombres feuillages proches
de la dentelle.

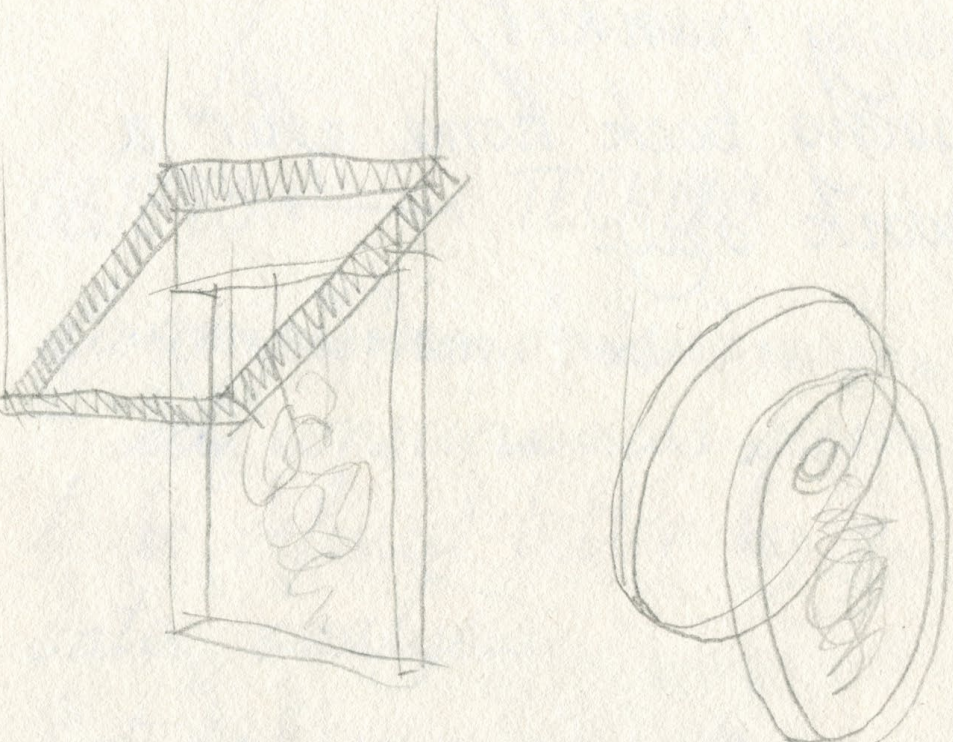

Everyone bringing
something up.
Hide the logistic behind.

Anni Albers.

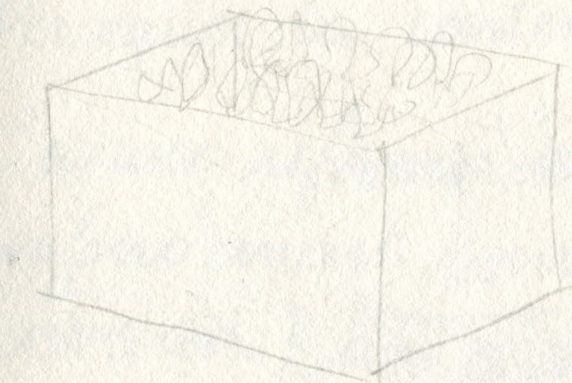

Inhance beauty, experimentes
from reality, real phenomena
"poetry" from every day situations

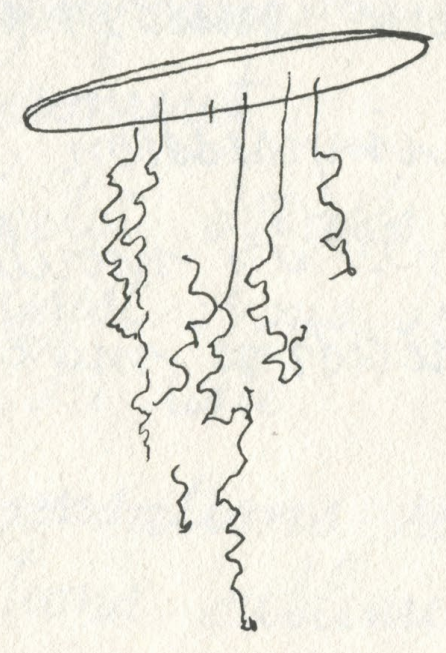

the jellyfish
mouvement
perpetuel
jeu d'ombres
son.



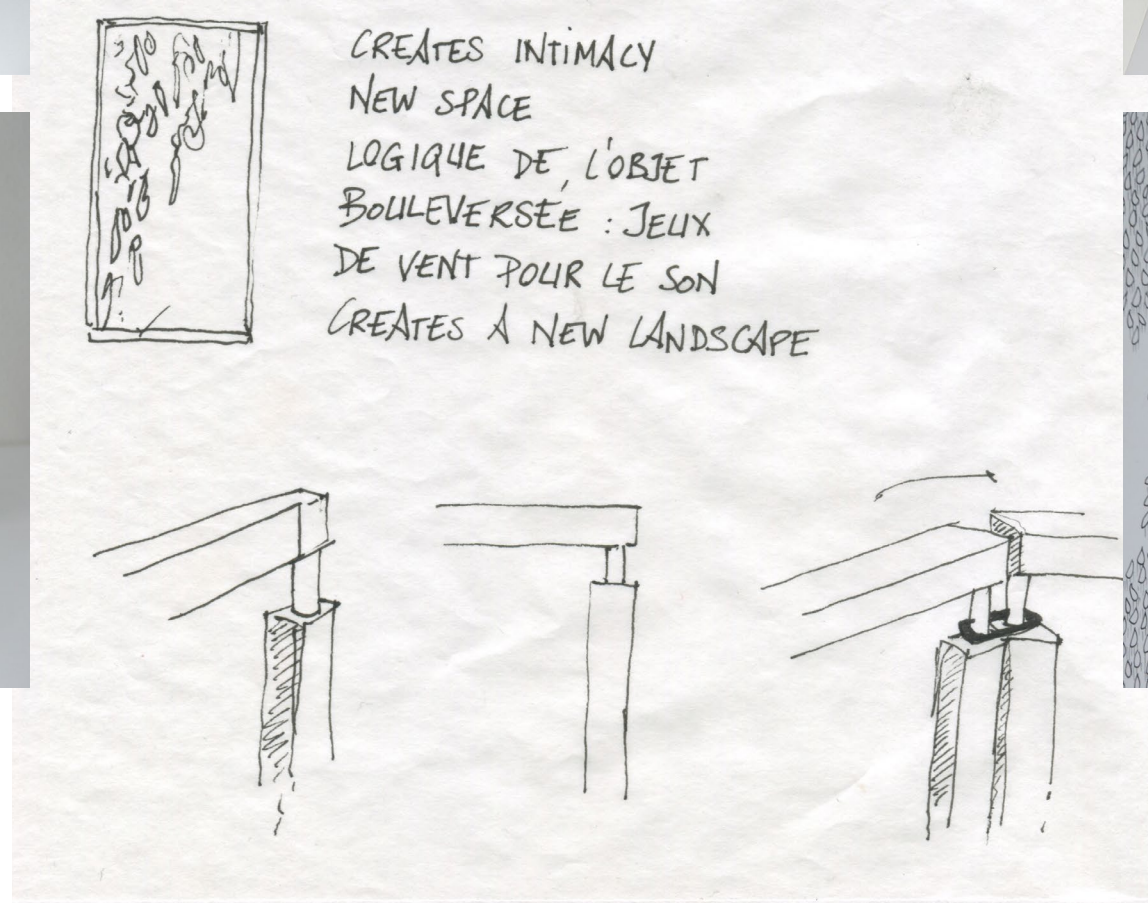
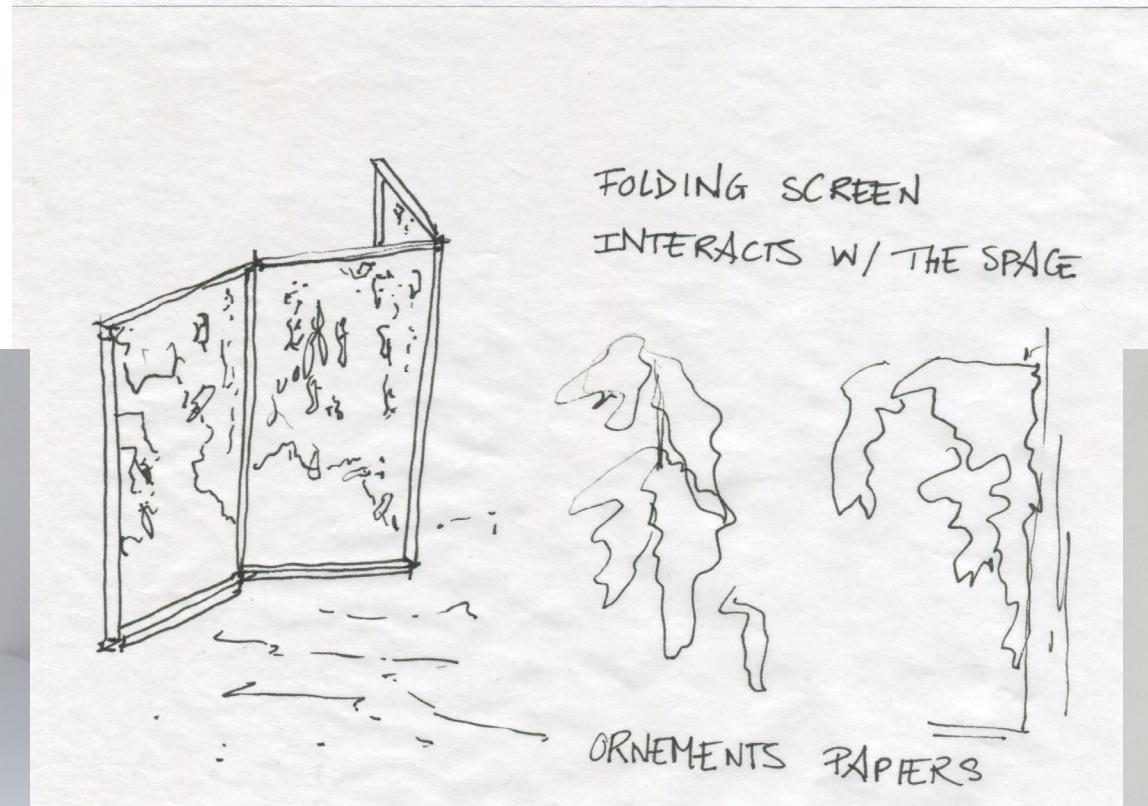



Format: GIF
Link [here](#)

② Paravent
Bois ; textile ; papier
trois panneaux.

textile
to purchase

pièces
de
bois
(CN)

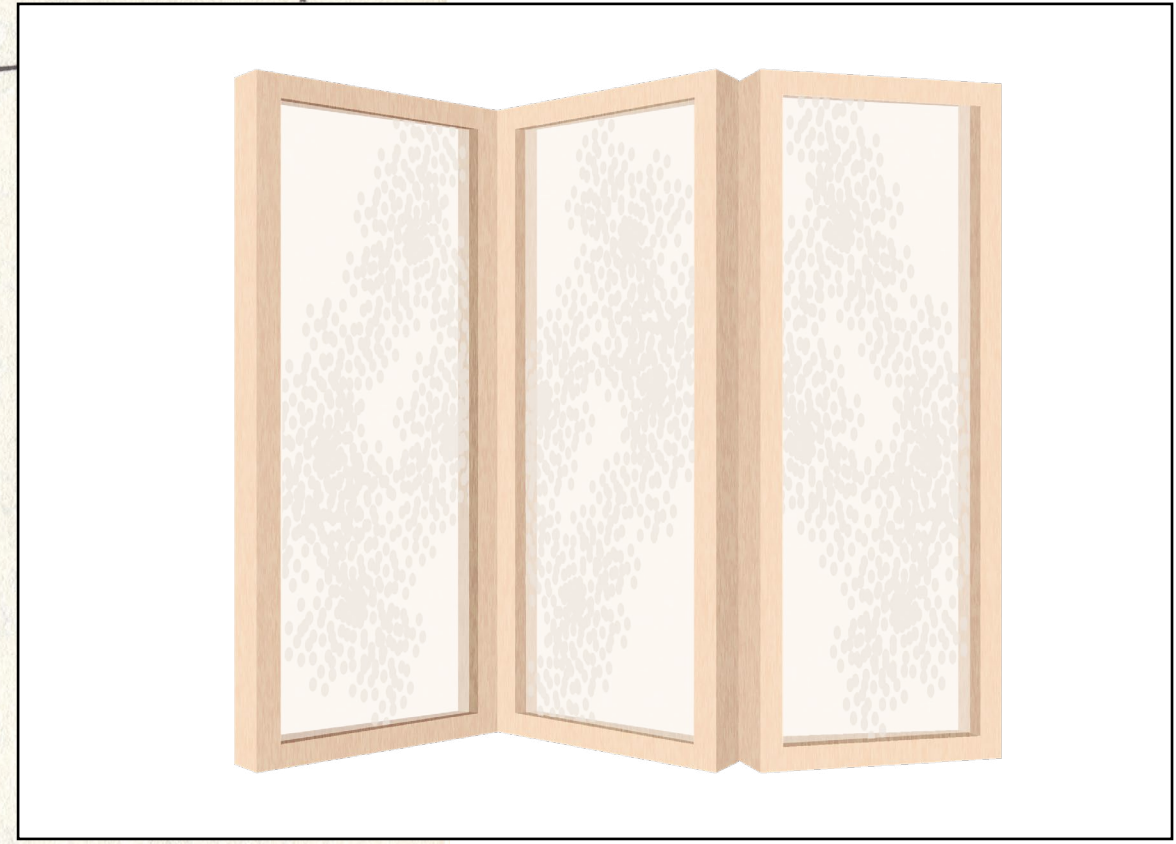
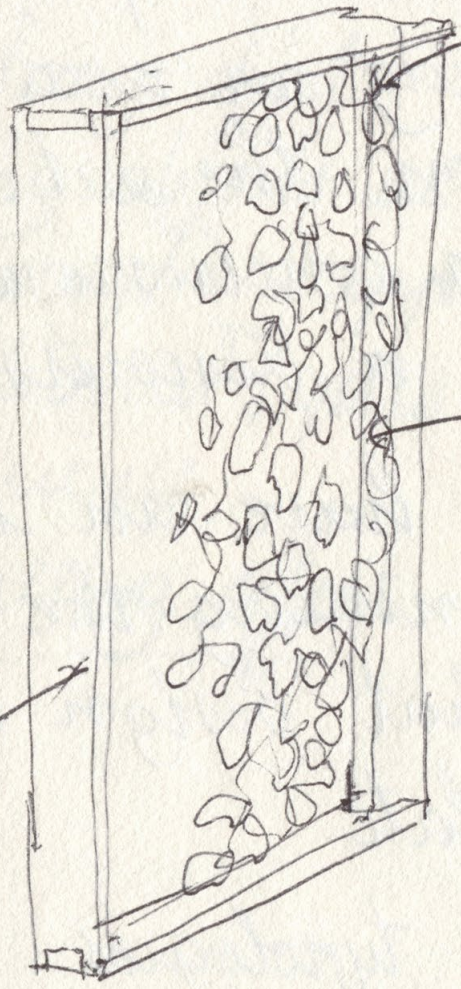

The folding screens originally aims at separating spaces, creating intimacy and protecting from the wind. Here, I enjoyed playing with the logic of the initial object: the transparency of the organza allows the light to penetrate and the wind to infiltrate. It slowly swings the sewn paper sheets, initiating a movement and a sound. The rustles of the baking paper, light and resistant to water and heat, recreate the murmurs of volatile leaves in the fall.

The different shapes of paper compose another kind of imaginary landscape that permanently changes depending on the lights and the orientation of the wooden frames. The object brings

attention to patterns and details, as it does not only remind one of the vegetation, but also these grandmother's lace curtains that recompose interior spaces with different nuances of shadows.

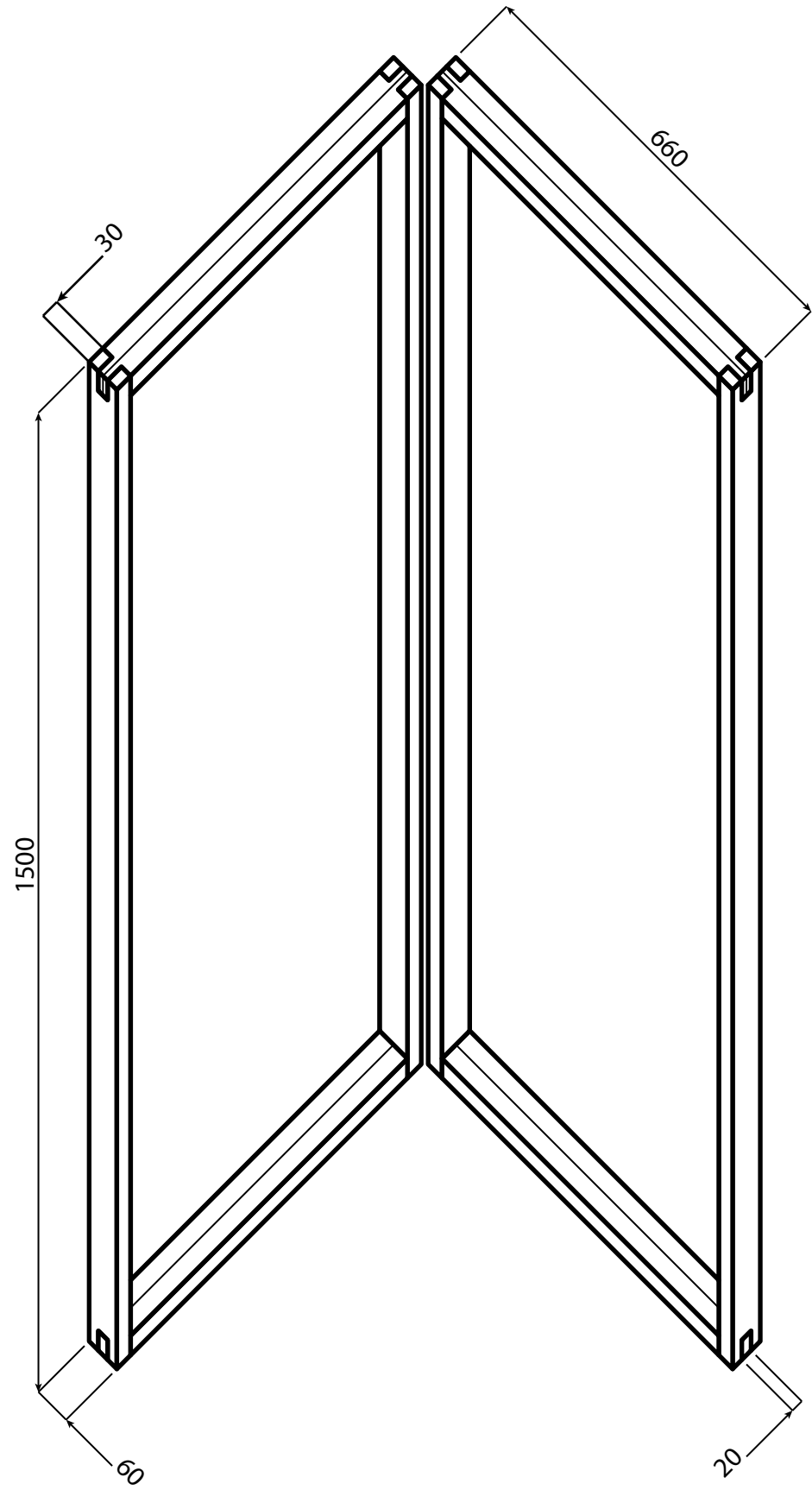

Technical drawings for
prototype #1

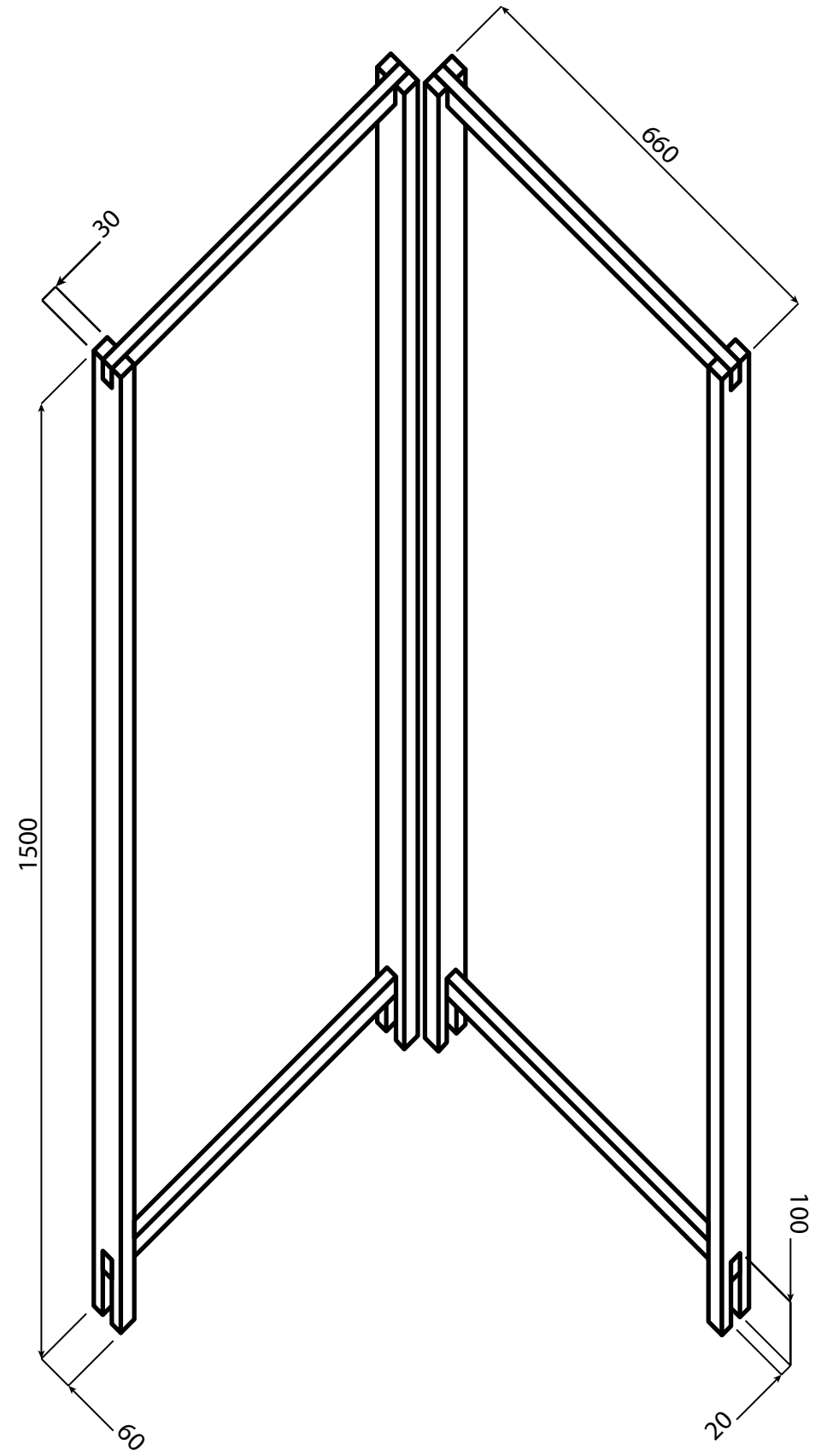

Technical drawings for
prototype #2

Leaves 'lace' #1
Oak tree

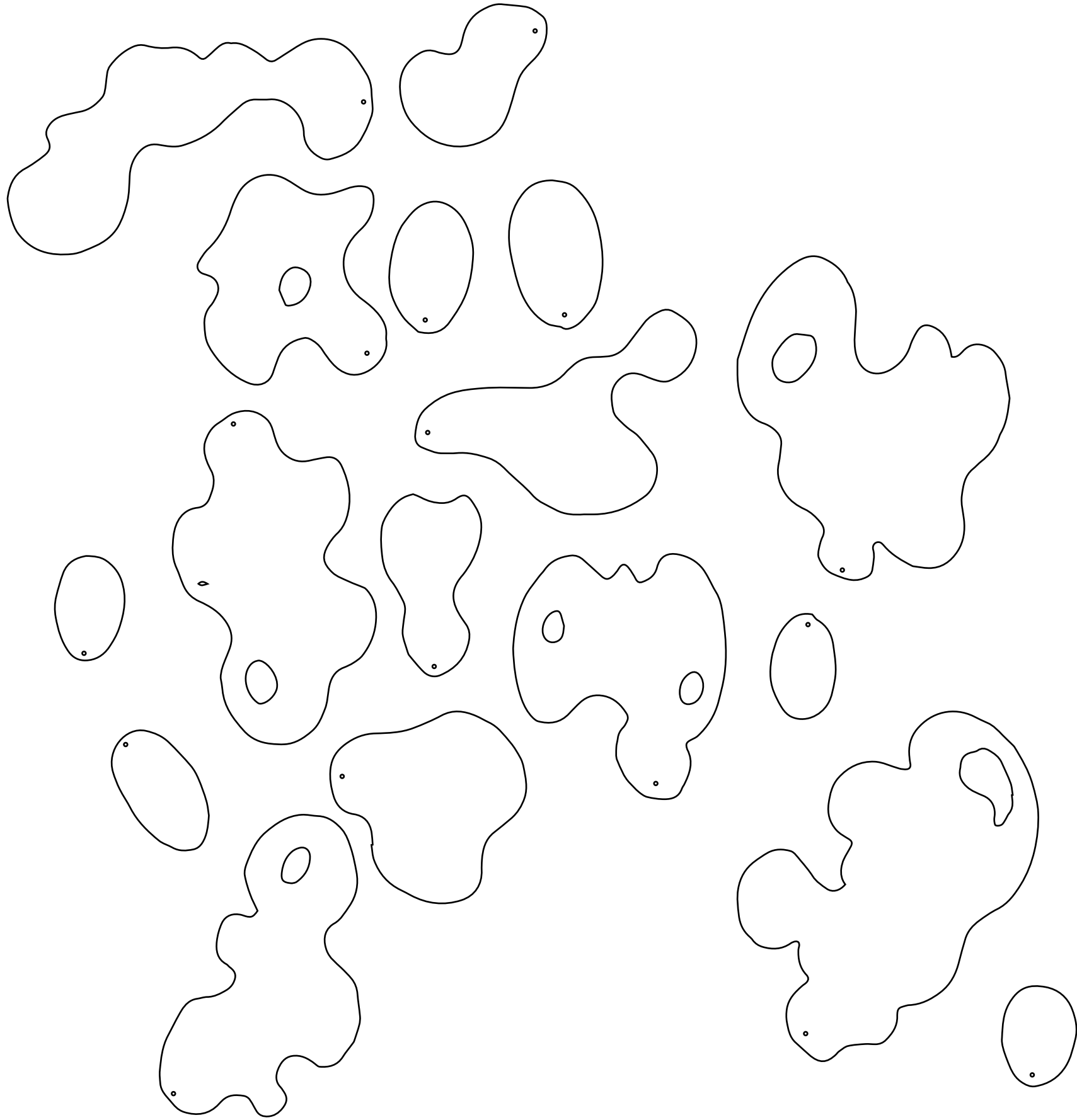

Baking paper cuttings
sewn on polyester organza

Leaves 'lace' #1
Olive tree

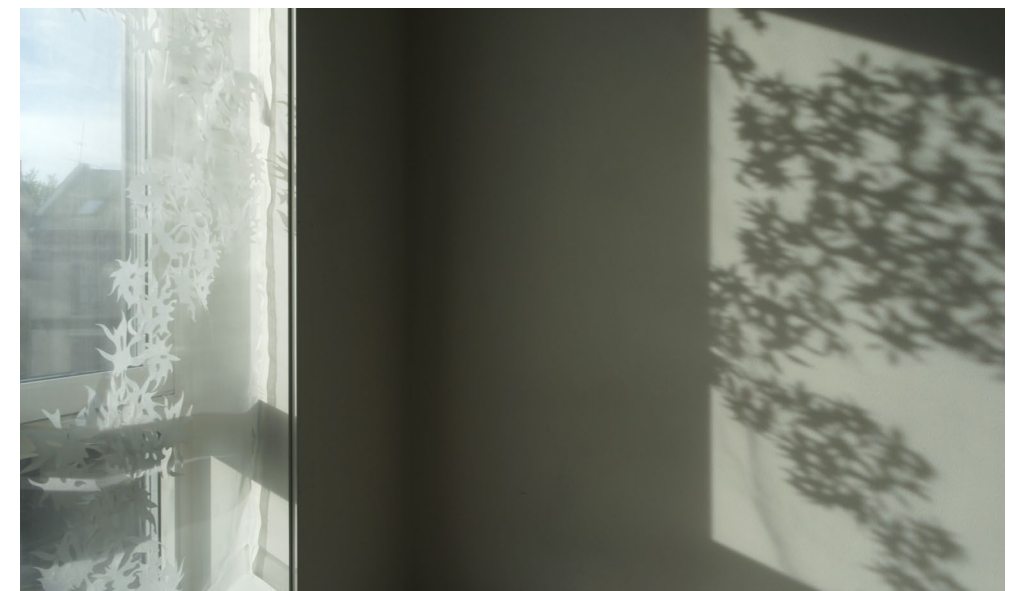

Baking paper cuttings
sewn on polyester organza





Particules and places

As I developed my investigation, the valorization of senses within the process became fundamental. Along the work, the smell appeared to be the most powerful, the most complete medium interconnecting both memories and reality, the extreme cohabitation of the present and the past. If the famous Madeleine of Proust is the perfect illustration, the same applies to the simple scents of shores, of leather or sunscreen. The smell undeniably allows experiences that are more precise, if not more immersive.



Picture from **The Anonymous Project**, anonymous photograph

Smell is complex. It is a presence and yet, an absence. It is a substance without a texture. And, it brought new challenges and new questionings to the investigation. How does immateriality influence reality? How to transliterate the preciseness, the delicateness of a smell? Something that we can remember. Something that we can guess without entirely grasping it, identifying it.

“Smell [...] is a highly elusive phenomenon. Odours, unlike colors, for instance, cannot be named – at least not in European languages. ‘It smells like...’, we have to say when describing an odour, groping to express our smell experience by means of metaphors. Nor can odours be recorded: there is no effective way of either capturing scents or storing them over time. In the realm of olfaction, we must make with descriptions and recollections.” (Constance Classen, David Howes, and Anthony Synnott, *Aroma: The cultural history of smell* (UK: Routledge, 1994))

'Particles and places' sets the final tone of the whole investigation: how to give words to sensations, objects to experiences, forms to the invisible. I used Sissel Tolaas' vocabulary of smell as a further development. Here, I started from the fact that the brain is conditioned to culturally associate colors and tastes, tastes and smells. And, the idea was to combine the psychology of colors with the taste in order to render the metaphorical 'look' of a scent that could be relatable.

Sissel Tolaas' smell dictionary

CLII: nature

DADO: dead leaves and compost

FRE: wet and rainy street after a sunny day

HAQSE: citrus fruits

HOZON: countryside

ISJ: grass

KANKALAY: smells that penetrate the air

FREEIS: leisure

LEUMEMO: water and ships

MAAR: penetrating seashore smell

MUKLUN: flowers; food and other sorts of comfortable smells

MUKSUN: mint; parsley; tobacco and other spices; some medicament

MUE LH'UN: unpleasant aromatic; sour

MUES'IN: charming; delicious; dulcet; lovely; smooth; sweet

PIISHE: importunate; intrusive; loud; obtrusive; pushful

POSIER: sand, dust and street stones

PUUHS: cigarettes - fresh French cigarettes

REEN: tree

SKENN: leather

SMASA: sand

SSISJ: sea grass

SQAHA: cooked food

UUJ: inimitable; peerless; remarkable; singular; unique

WIID: shore



Lumpy



Sweet



Earthy



Wet



Cold

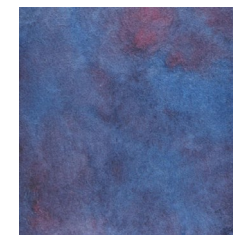

Chemical



Spicy

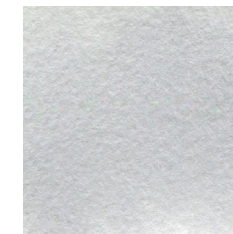

Ashy



Sour



Oaky



Old

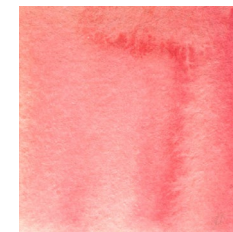

Fruity



Polluted

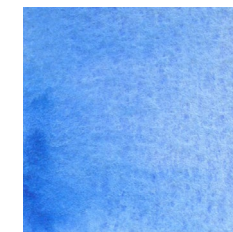

Salty



Brand new

The ordinary fragrances library



Sticky candies
MUES'IN



Wet macadam
FRE



Grandma's kitchen
SQAHA & MUKSUN



Cigaret at 8 a.m.
PUSH



Wooden floor
UUJ

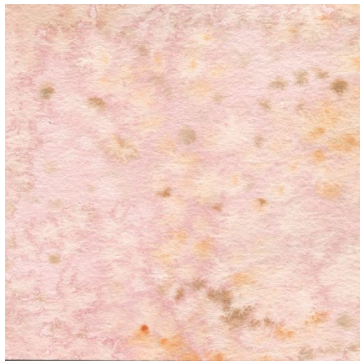

Sunburnt skin
FREEIS

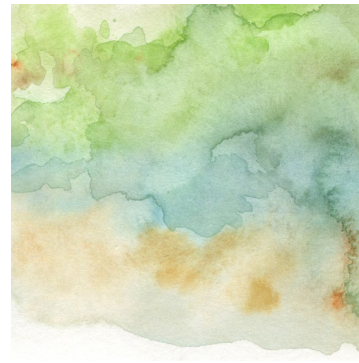

Walk in the woods
CLII & REEN

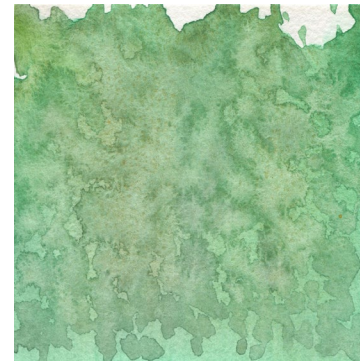

Picnic on the grass
ISJ

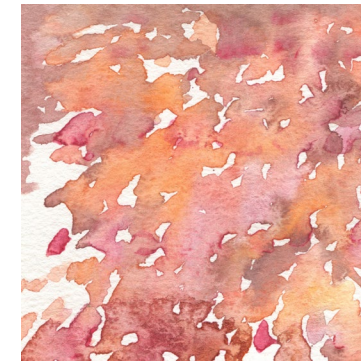

Autumnal soil
DADO



Heated leather car
PIISHE

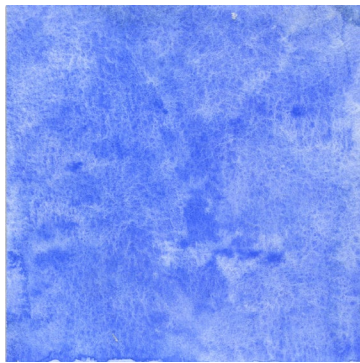

Open sea
LEUMEMO



Popsicle
HAQSE



Beach towel on sand
SMASA



Lemongrass
MUEH'UN



Terra cotta floor
POSIER



Altitude
HOZON

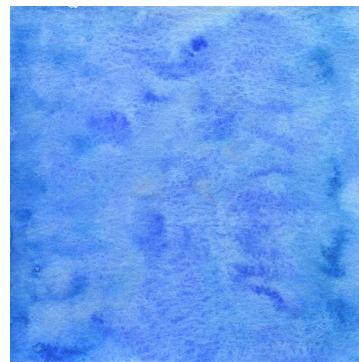

Mediterranean beach
SSISJ & MAAR



Flowers at the window
MUKLUN

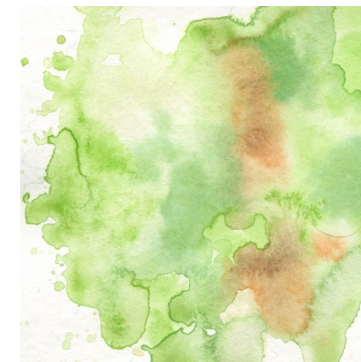

Pine wood
KANKALAY & WIID



Leather couch
SKENN

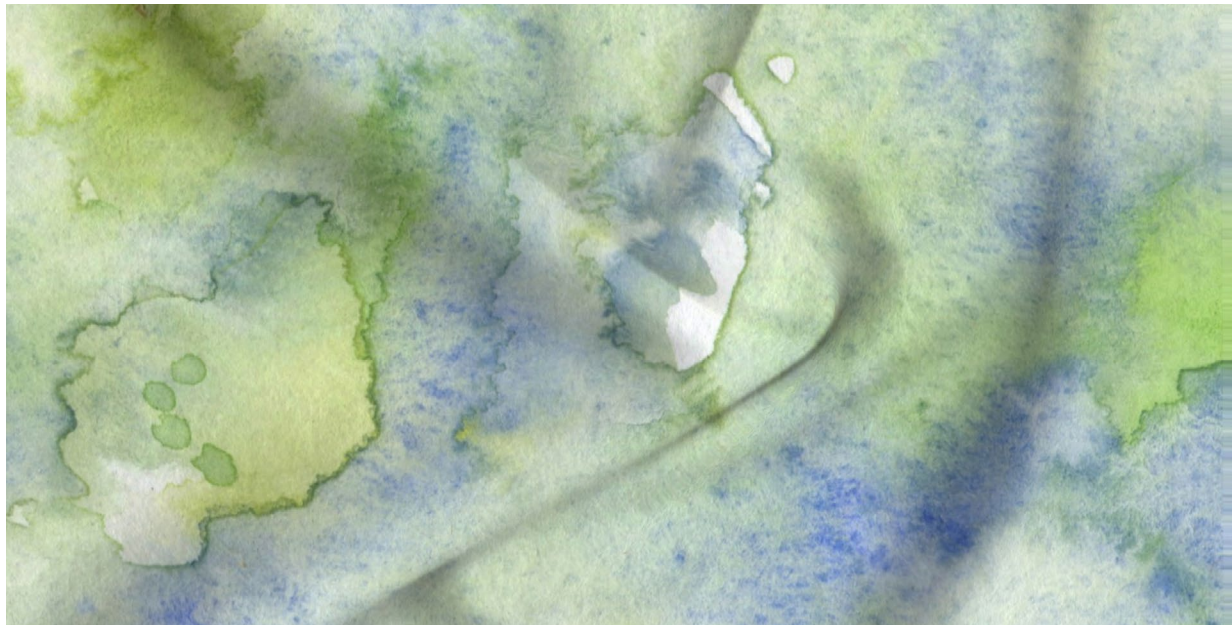

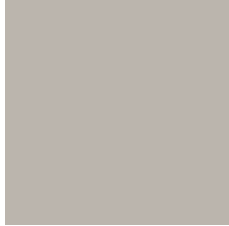
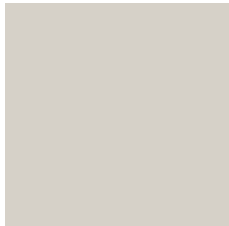
-  Linen
-  Cotton



-  Wool
-  Cotton



-  Viscose
-  Cotton

The relations between fabric and smell are immediately revealed by the comfort blankets, or the pleasure of smelling a beloved's scent on a sweater. Whether it is babies or lovers, fabric expresses the emotional extent of fragrances, because it is a metaphorical membrane, an intimate material as close as possible to the body. Following this idea, I imagined a series of textiles that comes with a series of scents. Each piece of fabric pairs with an 'ordinary fragrance': different materials completing different smells for various experiences.

How can I transfer this?
Isn't there something that
we can share?

How minds connect?
Check the email.

Ephimeral memories
Need to address: what
would the possibilities?
Create an environment of
remembrance.

Lay out how it could
work?

What are the parameters?
Get more into the sense
level.

Typology: what's made
the shape of that?
Famille avec les mêmes
gènes.

Patterns of recognition
Shared memories.
Shared space.

Appearance; methode;
share a same aspect.
what are the criteria that
make a family.

Between common and
stereotype.



Scent experiment,
first attempt of
capturing a smell.
Cypress infused in
jojoba oil.



Scent experiment,
second attempt of
capturing a smell.
Grass infused in
soja oil.

Smell # 1: pine wood.
 3 & Drops of pine needle $\frac{PNA}{LCY}$
 1 Drop of cypress
 25 ~~drops~~ of jojoba oil.



'A walk along the pine wood'
 Essential oils diluted and infused into jojoba oil

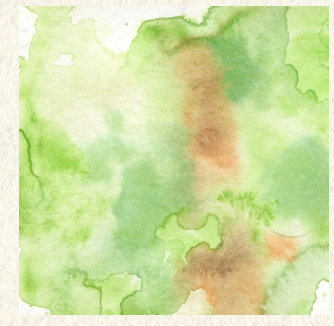

Frist, the sourness of the cypress scent, between citrus and lemongrass, only recalls the freshness of summer, of shores invaded by iodine. Then, the pine needle aroma, strong and yet pleasant, immediately sets the ambiance, where the feeling of the sticky nap almost appears.

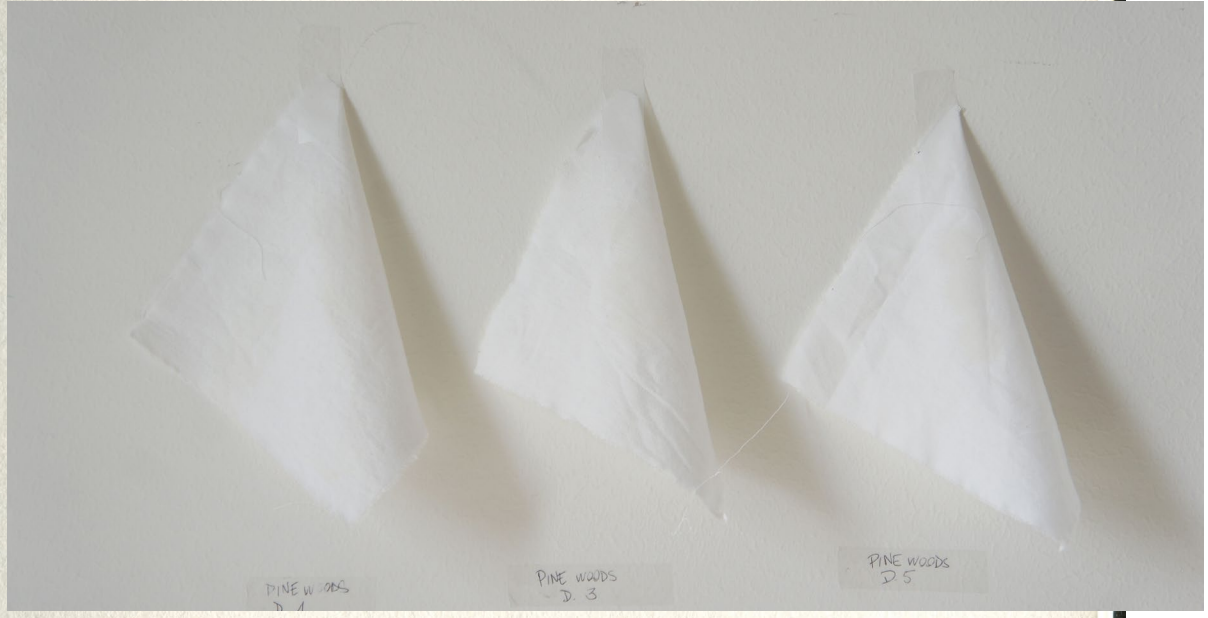

Format: GIF
 Link [here](#)

'A walk along
the pine wood'
Essential oils
diluted and
infused into
jojoba oil

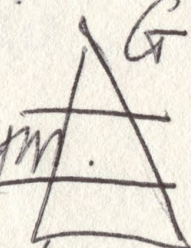

Smelle #2: countryside ✓
 1 thym blanc
 3 gouttes de genièvre
 20 doses d'huile de jojoba

thym. 

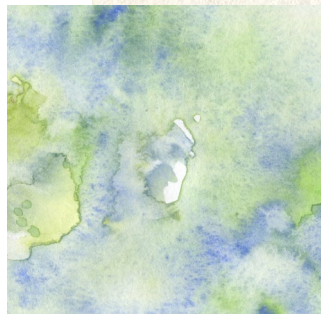

The air is always fresh, clean,
and around, endless vales
deprived of trees where only
short plants like thyme grow.
Yet, from the valleys above, the
air carries the humide scents
of other essences, fruitier,
sweeter.

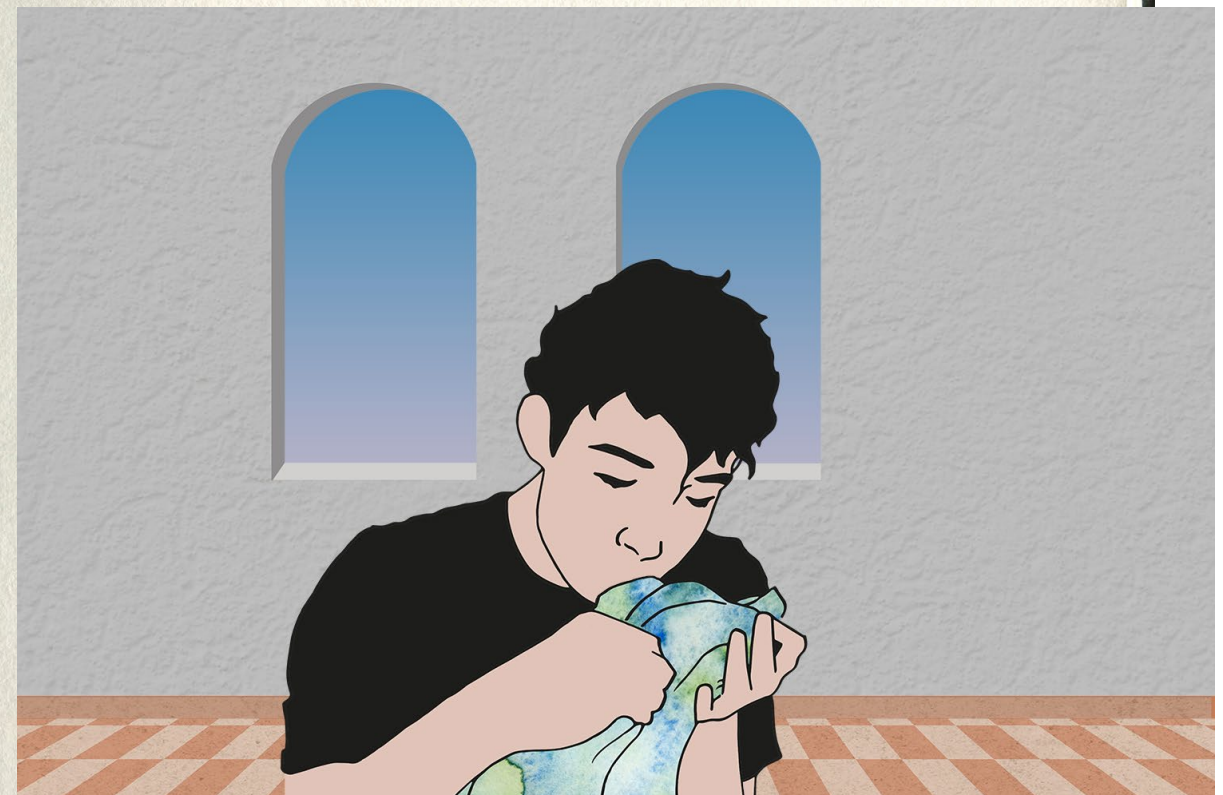
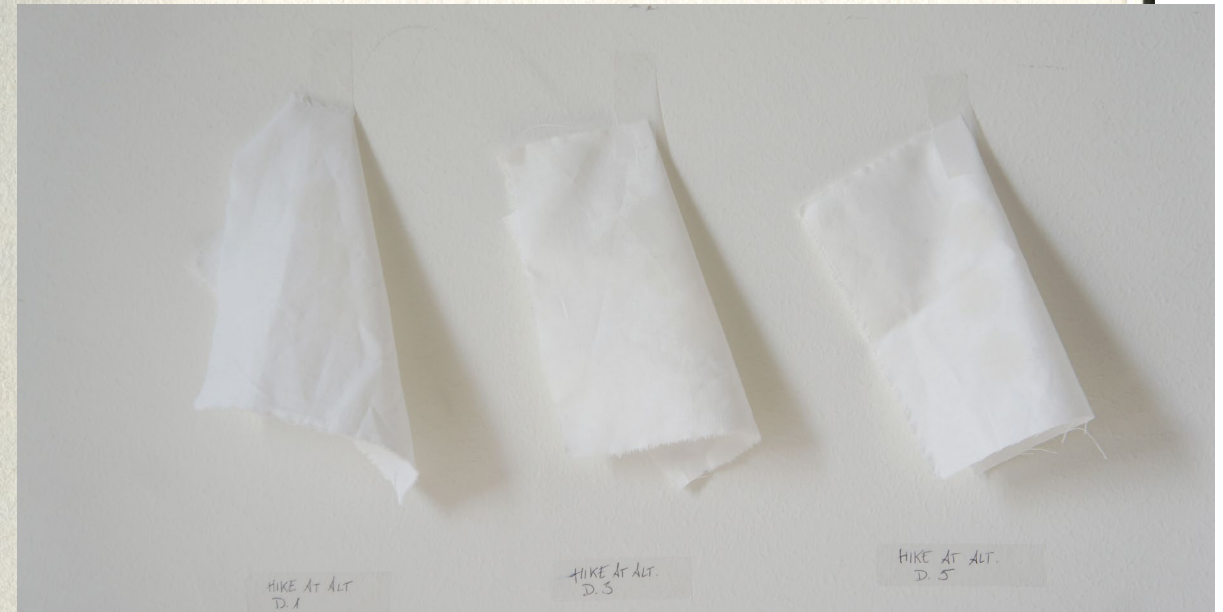

Format: GIF
Link [here](#)



Format: GIF
Link [here](#)



'In Search of Lost Times' explores objects as emotional extensions of oneself. It addresses memory as a key factor within our apprehension of materiality, spaces and objects. The connections between the materials, the senses, the colors, the lights and the atmosphere were essential in my process. They draw the lines of sensitivity, both in terms of sensitive perceptions and material experimentations.

The subjectivity of my project was a challenge, but it also nourished the work with new questions and new boundaries that actually helped me define my concept, and by extension, the idea of 'shared', 'relatable' or 'experience'. I led the work as an evolutive journey, a malleable investigation. I let my discovering and my questionings influence my directions, reinforce my choices and, step by step, complete my approach.

In better circumstances, I would have pushed my material research further: a broader experimentation for a better understanding of its possibilities. For instance, concerning the scent, I considered a field trip to Grasse, a city close to Nice of international renown for its fragrance industry. There, I would have benefited from the knowledge of professionals.

I took advantage of the practical semester to step out of my comfort zone and broaden my practice with materials I had never manipulated before. And, I believe that a thicker layer of experimentation and deeper knowledge would have enriched both my process and my production.

However, the lack of resources motivated my use of metaphors, narratives and speculations in my process, which I never dared to do before. A rearrangement of my methods and my expectations, in a context that Li Edelkoort rightly called the 'Age of Amateur'.



Camera foot

References

The Travelling Companions exhibitions

BALLARD Fay & GOLDHILL Judy

Curated by SPANKIE Ro

2017-

Common Spaces: The American Motel

BÉGOUT Bruce

2003

Autobiography of Objects

BON François

2012

Génie du non-lieu : air, poussière, empreinte, hantise

DIDI-HUBERMAN Georges

2001

The Delocazione series

PARMIGGIANI Claudio

1970-

In search of Lost Times

PROUST Marcel

1913-1917

Your Memories Are Idealized Versions of A Past That Doesn't Existed

SMALERA Paul

2017

The Anonymous Project

SHULMAN Lee

2017-

Nonsites

SMITHSON Robert

1968

The Re—Search Lab, Tolass Studio

TOLAAS Sissel

2004

Films

It's Only The End of The World

Xavier DOLAN

2016

The mattress scene

Link [here](#)

Harry Potter and the Deathly Hallows, part 2

David YATES

2011

The Pensieve scene

Link [here](#)